

Solinst® Mini Water Level Meter: Op Instructions

Model 102M

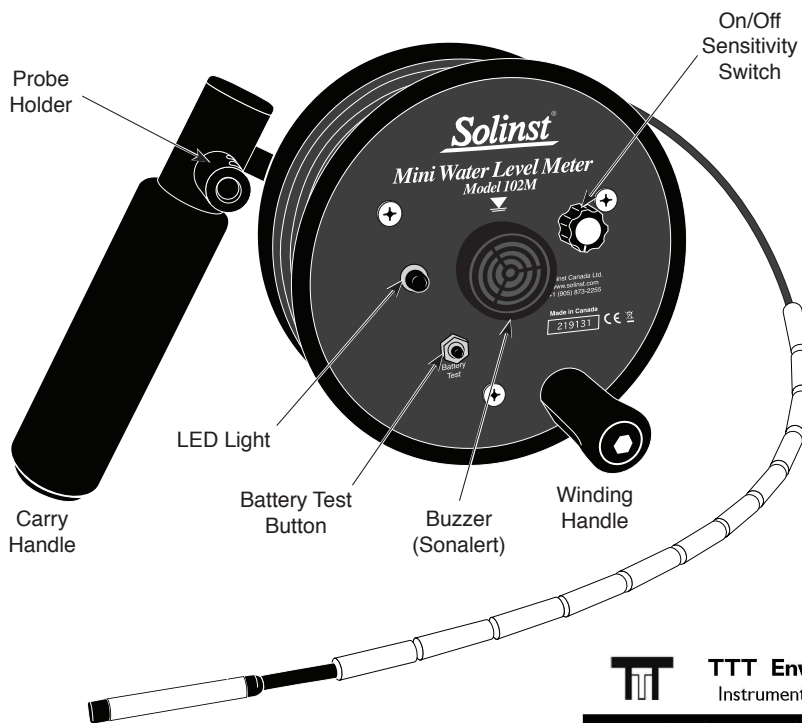

TTT Environmental
Instruments and Supplies

The preferred source for Instrument Rentals, Sales, Service and Supplies!

Available Probes: P1 & P2

4201 B Street
Anchorage, AK 99503
(907) 770-9041

www.tttenviro.com

25420 74th Avenue S.
Kent, VA 98032
(253) 373-9041

info@tttenviro.com

Water Level Measurements

1. The zero measurement point on both P1 and P2 Probes is the tip.
2. Feed the cable into the well. If a tape guide is used, lay the cable onto the groove on the top. Measurements will be read at the point of the V-notch on the tape guide. Remember to deduct 2/10 ft or 6.0 cm.
3. The light and buzzer activate when the probe tip enters water. To ensure accuracy, lower and raise the probe a few times and then record the depth measurement from the cable at the top of the well.

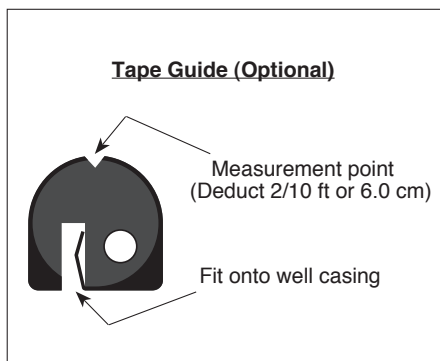

Equipment Check

1. Turn sensitivity switch **fully clockwise**.

Notes: 1. Clockwise rotation of sensitivity switch turns meter on and increases sensitivity.
2. Always set switch to highest sensitivity position, then decrease if necessary.

2. Depress the Battery Test button to test the battery and main circuitry.
3. Submerge the probe in tap water to test the probe. This completes the circuit and activates the buzzer and light.

Routine Care

1. After the depth to water has been recorded, the cable should be carefully rewound onto the reel, the probe wiped dry and placed into the probe holder.
2. The probe, weights, cable and reel can be wiped clean with phosphate free (non-abrasive) detergent and water. Do not submerge the reel.

Battery Replacement

- Battery type - alkaline, 9 volt.
1. The battery is housed within the faceplate of the reel.
 2. Using a Phillips screwdriver, remove the three screws on the faceplate.

3. Carefully remove the faceplate so as to not unwind the cable. Note that there is an elastic band keeping everything together in the faceplate.
4. While leaving the elastic band in place, replace the battery.
5. Carefully place the faceplate back onto the hub and line up the holes.

Note: Before screwing the faceplate back onto the hub, make sure no wires are outside the hub.

6. Once the screws have been tightened and the faceplate is secure, test the water level meter.

Replacement Parts

The following parts can be provided should components become lost or damaged.

1. Splice kits
2. Lights, switches, etc.
3. Reels
4. Replacement cable with probe (complete)
5. Assembled probes on 10 ft or 3 m lengths of cable
6. Probes and weights

Troubleshooting

SYMPTOM	CAUSE	REMEDY
No sound when probe immersed in water.	Dead battery.	Replace with 9V Alkaline.
	Water Conductivity is very low.	Increase sensitivity switch setting (turn clockwise) or call Solinst for assistance.
	Disconnected wires on circuit board.	Check all connections inside hub of reel for loose/disconnected wires - solder or reconnect.
	Broken wire in cable.	Locate break in cable - splice and seal, or replace. (Contact Solinst)
Instrument continuously sounds after being immersed in water.	Disconnected wire inside probe.	Contact Solinst to obtain parts/repair instructions.
	Water in probe. Probe may be dirty which could interfere with the circuit connection.	Contact Solinst for instructions to remove, clean and reseal the probe.

Printed in Canada
June 6, 2014

(#109409)

For further information contact: **Solinst Canada Ltd.**
Fax: +1 (905) 873-1992; (800) 516-9081 Tel: +1 (905) 873-2255; (800) 661-2023
35 Todd Road, Georgetown, Ontario Canada L7G 4R8
Web Site: www.solinst.com E-mail: instruments@solinst.com

Solinst®