



A Capital Safety Company

INSTRUCTION MANUAL

ANSI Z359.14 Class B

ANSI A10.32

This manual is intended to meet the Manufacturer's Instructions as required by ANSI Z359.14 and should be used as part of an employee training program as required by OSHA.

NANO-LOK™

SELF RETRACTING LIFELINES

Model Numbers: (See Figure 1)

Figure 1 – Nano-Lok™ Self Retracting Lifeline Models

		A - Steel Snap Hook	B - Steel Rebar Hook	C - Aluminum Rebar Hook	G - 3100089 Cab Mount	H - 3100088 Single Leg Interface	I - 3100087 Twin Leg Interface	K - 2000112 Steel Carabiner	L - 2000025 Aluminum Carabiner	M - Web Leg with Aluminum Snap Hook (F)	A - Steel Snap Hook	B - Steel Rebar Hook	C - Aluminum Rebar Hook	D - Steel Swiveling Snap Hook	E - Aluminum Carabiner (captive eye)	F - Aluminum Snap Hook	
Swivel End	Lanyard End	Model															
		Swivel End											Lanyard End				
Anchorage Connection Models 		3101214							1							1	
 K - 2000112 L - 2000025		3101215						1			1						
 A B C D E F		3101216						1					1				
		3101217						1			1						
		3101218	1							1							
		3101219	1								1						
		3101235							1						1		
		3101236							1			1					
		3101237		1											1		
		3101238		1												1	
		3101241	1											1			
Single SRL Harness Mount Models 		3101225				1									1		
 A B C D E F		3101226				1									1		
 A B C D E F		3101227				1						1					
		3101228				1					1						
		3101229				1						1					
		3101253				1							1				
Twin SRL Harness Mount Models 		3101275					1								2		
 A B C D E F		3101276					1								2		
NOTE: Older ExoFit harnesses may require different Twin SRL models. See Appendix A.		3101277					1						2				
		3101278					1							2			
		3101279					1				2						
		3101280					1					2					
Cab Mount (Order Picker) Models 		3101239			1									1			
 A D		3101240			1						1						

(See next page for Arc Flash models...)

Figure 1 – Nano-Lok™ Self Retracting Lifeline Models

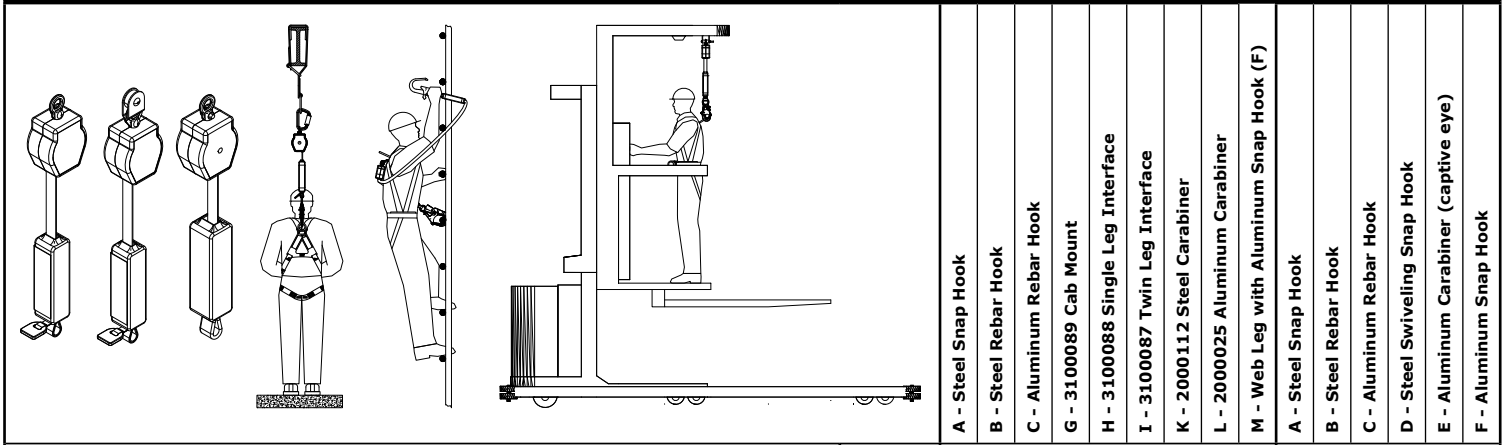

- A - Steel Snap Hook
- B - Steel Rebar Hook
- C - Aluminum Rebar Hook
- G - 3100089 Cab Mount
- H - 3100088 Single Leg Interface
- I - 3100087 Twin Leg Interface
- K - 2000112 Steel Carabiner
- L - 2000025 Aluminum Carabiner
- M - Web Leg with Aluminum Snap Hook (F)
- A - Steel Snap Hook
- B - Steel Rebar Hook
- C - Aluminum Rebar Hook
- D - Steel Swiveling Snap Hook
- E - Aluminum Carabiner (captive eye)
- F - Aluminum Snap Hook

Swivel End	Lanyard End	Model	Swivel End		Lanyard End		
<p>H - 3100088</p> <p>Arc Flash¹ Single SRL Harness Mount Models</p>		3101360	1			1	
		3101361	1		1		
		3101362	1		1		
		3101363	1				1
		3101364	1			1	
<p>I - 3100087</p> <p>Arc Flash¹ Twin SRL Harness Mount Models</p>		3101380		1		2	
		3101381		1			2
		3101382		1		2	
		3101383		1			2
		3101384		1		2	
<p>K</p> <p>M</p> <p>Arc Flash¹ Anchorage Connection Models</p>		3101385		1		1	
		3101375			1		1
		3101358			1		

Model 3101375 Bucket Truck Application

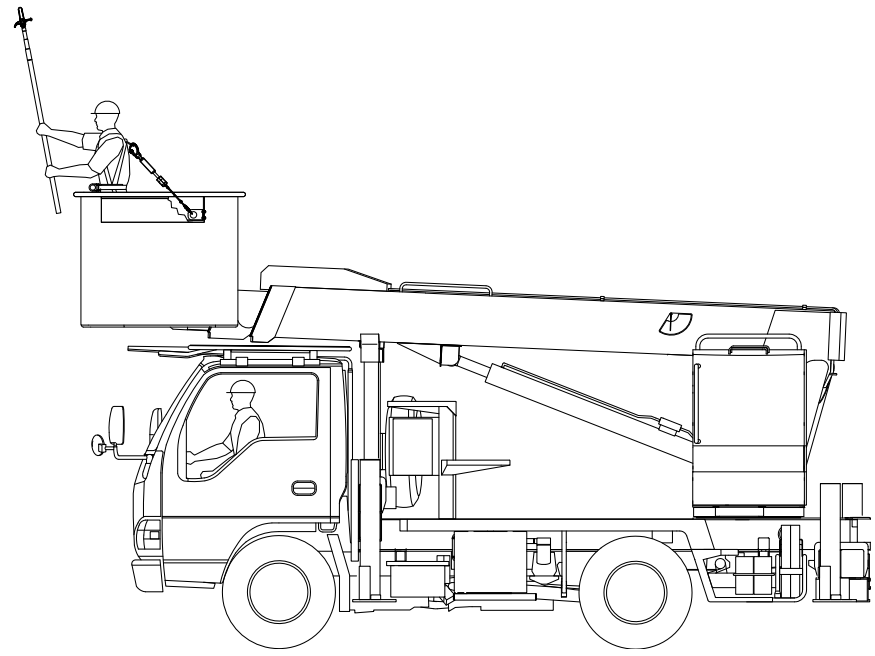

¹ **Arc Flash:** SRL meets the test requirements of the ASTM F887-11 standard and is designed for use in environments where an arc flash (electrical explosion) could occur.

WARNING: This product is part of a personal fall arrest, work positioning, or rescue system. The user must follow the manufacturer's instructions for each component of the system. These instructions must be provided to the user of this equipment. The user must read and understand these instructions before using this equipment. Manufacturer's instructions must be followed for proper use and maintenance of this equipment. Alterations or misuse of this product or failure to follow instructions may result in serious injury or death.

IMPORTANT: If you have questions on the use, care, or suitability of this equipment for your application, contact Capital Safety.

IMPORTANT: Before using this equipment, record the product identification information from the ID label in the inspection and maintenance log of this manual.

DESCRIPTIONS:

Figure 2 illustrates key components of the base Nano-Lok™ Self Retracting Lifeline (SRL). The Nano-Lok SRLs are 6 ft. (1.8 m) lanyards, equipped with an in-line Load Indicator, which retract into a Thermoplastic Housing. They are available in multiple model configurations that allow attachment to an anchorage point, single or dual mounting on a Full Body Harness, or cab mounting on an Order Picker or similar equipment (see Figure 1). The Nano-Lok SRL automatically locks at the onset of a fall to arrest the fall, but pays out and retracts lifeline during normal movement by the attached user.

Figure 2 – Nano-Lok Self Retracting Lifeline (SRL) Components

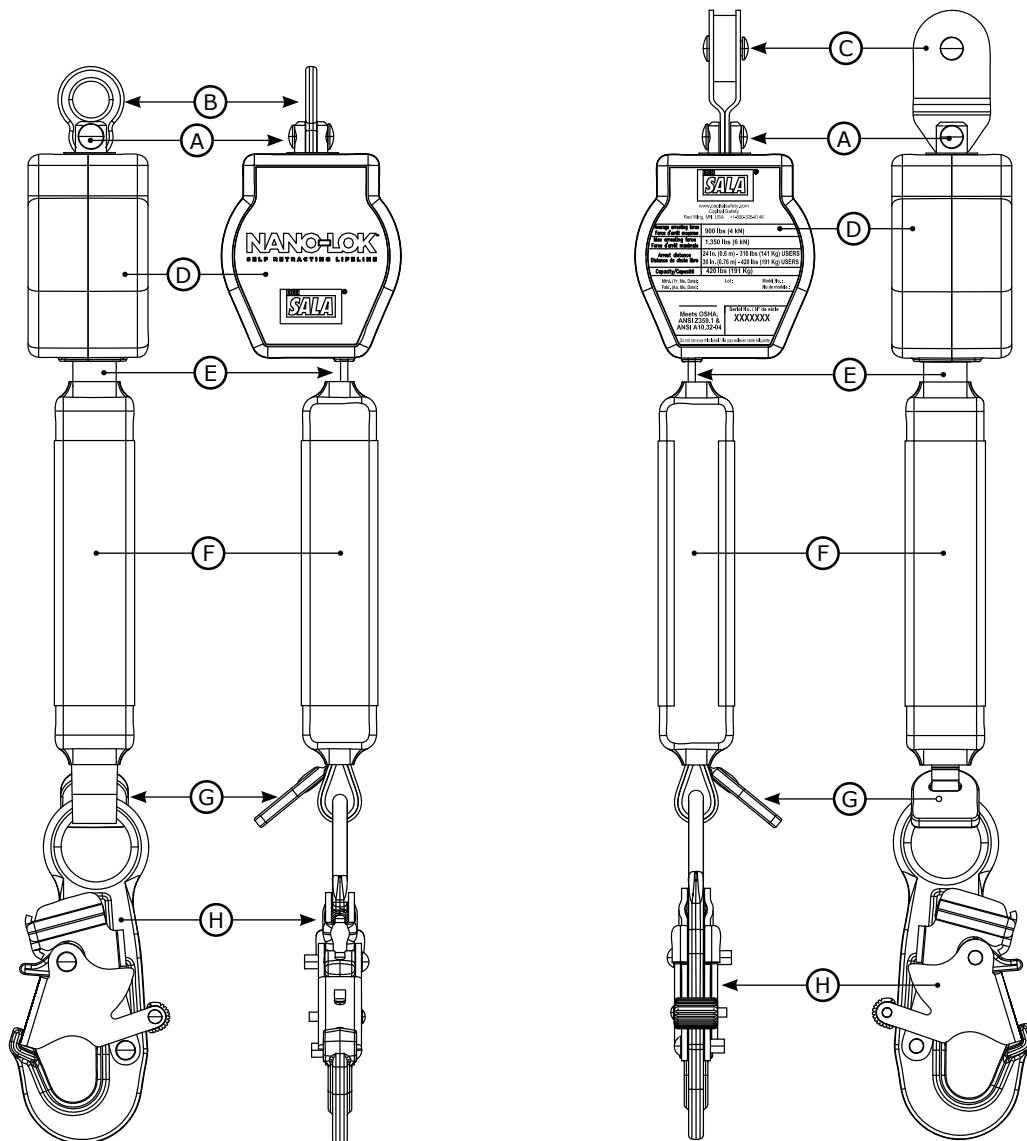

A - Swivel **B** - Swivel Eye **C** - Integral Connector **D** - Housing **E** - Web Lifeline **F** - Load Indicator **G** - iSafe™ RFID Tag
H - Snap Hook

1.0 APPLICATIONS

- 1.1 PURPOSE:** Capital Safety Self Retracting Lifelines (SRLs) are designed to be a component in a personal fall arrest system (PFAS). Figure 1 illustrates SRLs covered by this instruction manual and their typical applications. They may be used in most situations where a combination of worker mobility and fall protection is required (i.e. inspection work, general construction, maintenance work, oil production, confined space work, etc.).
- 1.2 STANDARDS:** Your SRL conforms to the national standard(s) identified on the front cover of these instructions. Refer to local, state, and federal (OSHA) requirements governing occupational safety for additional information regarding Personal Fall Arrest Systems. Refer to the following national standards on fall protection:

ANSI	Z359.0	Definitions and Nomenclature Used for Fall Protection and Fall Arrest
ANSI	Z359.1	Safety Requirements for Personal Fall Arrest Systems, Subsystems, and Components
ANSI	Z359.2	Minimum Requirements for a Comprehensive managed Fall Protection Program
ANSI	A10.32	Personal Fall Protection use in Construction and Demolition

- 1.3 TRAINING:** This equipment is intended to be used by persons trained in its correct application and use. It is the responsibility of the user to assure they are familiar with these instructions and are trained in the correct care and use of this equipment. Users must also be aware of the operating characteristics, application limits, and the consequences of improper use.

2.0 LIMITATIONS & REQUIREMENTS

Always consider the following limitations and requirements when installing or using this equipment:

- 2.1 CAPACITY:** SRLs are designed for use by one person with a combined weight (person, clothing, tools, etc.) not exceeding 420 lbs (190 kg).
At no time shall more than one person connect to a single SRL for fall arrest applications.
- 2.2 MAXIMUM ARREST FORCE AND MAXIMUM ARREST DISTANCE:** SRLs documented in this instruction meet the following Arrest Force and Arrest Distance maximums:

Weight of Worker	Up to 310 lbs (141 kg)	Greater than 310 lbs (141 kg) Up to 420 lbs (191 kg)
Average Arresting Force	900 lbs (4.0 kN)	900 lbs (4.0 kN)
Maximum Arresting Force	1,350 lbs (6.0 kN)	1,350 lbs (6.0 kN)
Maximum Arrest Distance	30 in (0.76 m)	36 in (0.9 m)

- 2.3 ANCHORAGE:** Anchorages selected for fall arrest systems shall have a strength capable of sustaining static loads applied in the directions permitted by the system of at least:
- 5,000 lbs. (22.2 kN) for non-certified anchorages, or
 - Two times the maximum arresting force for certified anchorages.

When more than one fall arrest system is attached to an anchorage, the strengths set forth in (1) and (2) above shall be multiplied by the number of systems attached to the anchorage.

FROM OSHA 1926.500 AND 1910.66: Anchorages used for attachment of personal fall arrest systems shall be independent of any anchorage being used to support or suspend platforms, and capable of supporting at least 5,000 lbs. per user attached, or be designed, installed, and used as part of a complete personal fall arrest systems which maintains a safety factor of at least two, and is under the supervision of a qualified person.

- 2.4 RESCUE PLAN:** When using this equipment, the employer must have a rescue plan and the means at hand to implement it and communicate that plan to users, authorized persons, and rescuers.
- 2.5 INSPECTION FREQUENCY:** SRLs shall be inspected by the authorized person¹ or rescuer² before each use. Additionally, inspections shall be conducted by a competent person³ other than the user, and by a factory authorized inspection entity. The competent person shall use the Inspection Schedule (Table 1) to determine appropriate inspection intervals. Inspection procedures are described in the "Inspection Checklist" (Table 2). Results of the Competent Person inspection should be recorded in the "Inspection and Maintenance Log" on the back pages of these instructions or recorded with the i-Safe™ system (see Section 5).

1 Authorized Person: A person assigned by the employer to perform duties at a location where the person will be exposed to a fall hazard.

2 Rescuer: Person or persons other than the rescue subject acting to perform an assisted rescue by operation of a rescue system.

3 Competent Person: An individual designated by the employer to be responsible for the immediate supervision, implementation, and monitoring of the employer's managed fall protection program who, through training and knowledge, is capable of identifying, evaluating, and addressing existing and potential fall hazards, and who has the employer's authority to take prompt corrective action with regard to such hazards.

Table 1 – Inspection Schedule

Type of Use	Application Examples	Conditions of Use	Inspection Frequency	
			Competent Person	Factory Authorized
Infrequent to Light	Rescue and Confined Space, Factory Maintenance	Good Storage Conditions, Indoor or Infrequent Outdoor Use, Room Temperature, Clean Environments	Annually	At Least Every 2-5 Years, but not longer than intervals required by the manufacturer
Moderate to Heavy	Transportation, Residential Construction, Utilities, Warehouse	Fair Storage Conditions, Indoor and Extended Outdoor Use, All Temperatures, Clean or Dusty Environments	Semi-Annually to Annually	At Least Every 1-2 Years, but not longer than intervals required by the manufacturer
Sever to Continuous	Commercial Construction, Oil and Gas, Mining	Harsh Storage Conditions, Prolonged or Continuous Outdoor Use, All Temperatures, Dirty Environment	Quarterly to Semi-Annually	At Least Annually, but not longer than intervals required by the manufacturer

- 2.6 LOCKING SPEED:** Situations which do not allow for an unobstructed fall path should be avoided. Working in confined or cramped spaces may not allow the body to reach sufficient speed to cause the SRL to lock if a fall occurs. Working on slowly shifting material, such as sand or grain, may not allow enough speed buildup to cause the SRL to lock. A clear path is required to assure positive locking of the SRL.
- 2.7 NORMAL OPERATIONS:** Normal operation will allow the full length of the lifeline to extend and retract with no hesitation when extending and no slack when retracting as the worker moves at normal speeds. If a fall occurs, a speed sensing brake system will activate, stopping the fall and absorbing much of the energy created. For falls which occur near the end of the lifeline travel, a reserve lifeline system or Load Indicator has been incorporated to assure a reduced impact fall arrest. If the SRL has been subjected to fall forces, remove the SRL from service, mark "UNUSABLE", and dispose of in the recommended manner (see "Section 5.5 - Disposal"). Sudden or quick movements should be avoided during normal work operation, as this may cause the SRL to lock up.
- 2.8 FREE FALL:** When anchored overhead, SRLs will limit the free fall distance to 2 ft. (61 cm) or less. To avoid increased fall distances, anchor the SRL directly above the work level. Avoid working where your lifeline may cross or tangle with that of another worker. Avoid working where an object may fall and strike the lifeline; resulting in loss of balance or damage to the lifeline. Do not allow the lifeline to pass under arms or between legs. Never clamp, knot, or prevent the lifeline from retracting or being taut. Avoid slack line. **Do not lengthen SRL by connecting a lanyard or similar component without consulting Capital Safety.**
- 2.9 FALL CLEARANCE:** Figure 3A illustrates Fall Clearance requirements. Ensure adequate clearance exists in the fall path to prevent striking an object during a fall. If the worker will be working at a position that is not directly below the SRL anchorage point, the clearance required and vertical fall distance will be greater.
- 2.10 SWING FALLS:** Swing falls occur when the anchorage point is not directly above the point where a fall occurs (see Figure 3B). The force of striking an object in a swing fall may cause serious injury. In a swing fall, the total vertical fall distance will be greater than if the user had fallen directly below the anchorage point, thus increasing fall clearance required to safely arrest the user. Use Figure 3A to determine the fall clearance for your application. Minimize swing falls by working as directly below the anchorage point as possible. Never permit a swing fall if injury could occur.
- 2.11 HAZARDS:** Use of this equipment in areas where surrounding hazards exist may require additional precautions to reduce the possibility of injury to the user or damage to the equipment. Hazards may include, but are not limited to: high heat, caustic chemicals, corrosive environments, high voltage power lines, explosive or toxic gases, moving machinery, sharp edges, or overhead materials that may fall and contact the user or fall arrest system.
- 2.12 SHARP EDGES:** Avoid working where the lifeline will be in contact with or abrade against unprotected sharp edges. Where contact with a sharp edge is unavoidable, cover the edge with a protective material.
- 2.13 BODY SUPPORT:** A Full Body Harness must be used with the Self Retracting Lifeline. The harness connection point must be above the user's center of gravity. A body belt is not authorized for use with the Self Retracting Lifeline. If a fall occurs when using a body belt it may cause unintentional release and possible suffocation because of improper body support.
- 2.14 COMPATIBILITY OF COMPONENTS:** Unless otherwise noted, Capital Safety equipment is designed for use with Capital Safety approved components and subsystems only. Substitutions or replacements made with non approved components or subsystems may jeopardize compatibility of equipment and may affect safety and reliability of the complete system.

IMPORTANT: Read and follow manufacturer's instructions for associated components and subsystems in your personal fall arrest system.

Figure 3 – Fall Clearance and Swing Falls

Figure 3A:

Clearance required in feet (meters) between Working Level and Nearest Obstruction for User with Total Weight up to 310 lbs (141 kg)

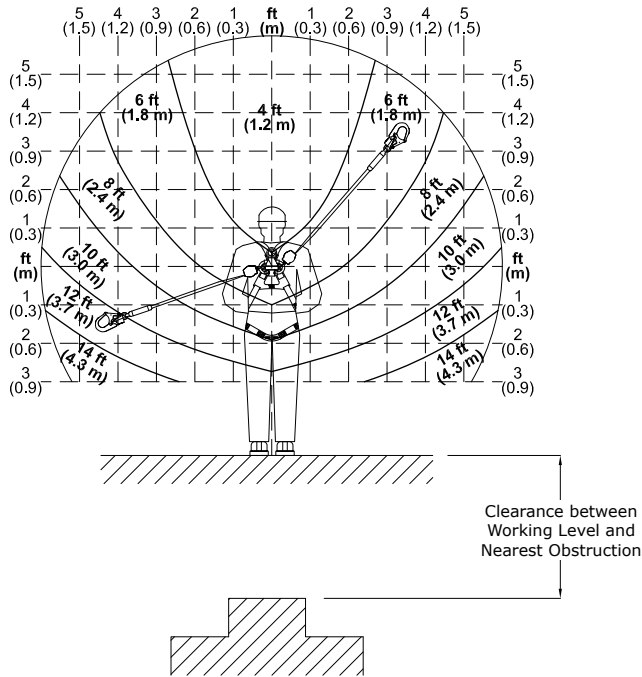
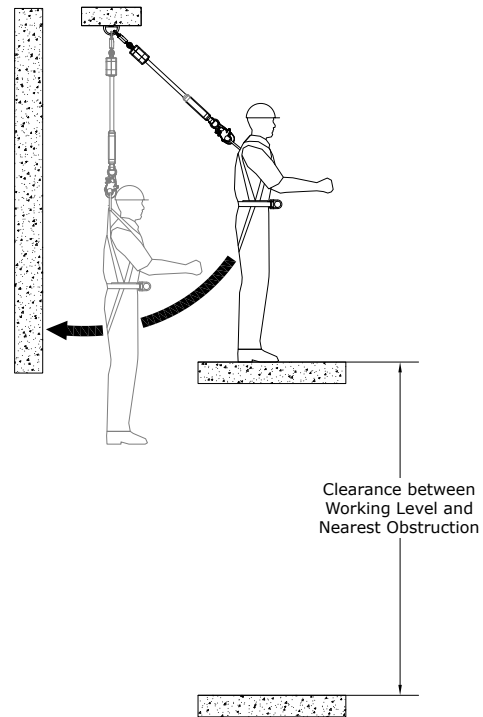

Figure 3B:

Swing Falls



To determine the clearance required: Measure the distance from the user's harness dorsal connection to the anchorage for the Nano-Lok SRL. Both horizontal and vertical distances are required. Use Figure 3A above to determine the required clearance. The dotted lines in the figure represent 1 foot (0.3 m) increments from the user's harness dorsal connection to the anchorage. For example, 6 ft (1.8 m) of clearance is required when the Nano-Lok unit is anchored 3 1/2 ft (1 m) above and 3 1/2 ft (1 m) to the side of the user's harness dorsal connection, 12 ft (3.7 m) of clearance is required when the Nano-Lok is anchored 1 1/2 ft (0.5 m) below and 4 1/2 ft (1.4 m) to side of the user's dorsal connection.

NOTE: The clearances provided above assume the fall occurs from the standing position. If the worker is kneeling or crouching an additional 3 ft (0.9 m) of clearance is needed.

USERS BETWEEN 310 AND 420 LBS (141-191 kg): Users with a combined weight (person, clothing, tools, etc.) between 310 and 420 lbs (141-191 kg) need 1 ft (0.3 m) more clearance than what is shown in the Figure 3A. 310 lb to 420 lb (141-191 kg) users must never anchor the Nano-Lok more than 2 ft (0.6 m) below their harness dorsal connection.

2.15 COMPATIBILITY OF CONNECTORS: Connectors are considered to be compatible with connecting elements when they have been designed to work together in such a way that their sizes and shapes do not cause their gate mechanisms to inadvertently open regardless of how they become oriented. Contact Capital Safety if you have any questions about compatibility.

Connectors (hooks, carabiners, and D-rings) must be capable of supporting at least 5,000 lbs. (22.2 kN). Connectors must be compatible with the anchorage or other system components. Do not use equipment that is not compatible. Non-compatible connectors may unintentionally disengage (see Figure 4). Connectors must be compatible in size, shape, and strength. Self-locking snap hooks and carabiners are required by ANSI Z359 and OSHA.

2.16 MAKING CONNECTIONS: Snap hooks and carabiners used with this equipment must be self-locking. Ensure all connections are compatible in size, shape and strength. Do not use equipment that is not compatible. Ensure all connectors are fully closed and locked.

Capital Safety connectors (snap hooks and carabiners) are designed to be used only as specified in each product's user's instructions. See Figure 5 for examples of inappropriate connections. Do not connect snap hooks and carabiners:

- A. To a D-ring to which another connector is attached.
- B. In a manner that would result in a load on the gate.

NOTE: Large throat snap hooks should not be connected to standard size D-rings or similar objects which will result in a load on the gate if the hook or D-ring twists or rotates, unless the snap hook complies with ANSI Z359.1-2007 or ANSI Z359.12 and is equipped with a 3,600 lb (16 kN) gate. Check the marking on your snap hook to verify that it is appropriate for your application.

- C. In a false engagement, where features that protrude from the snap hook or carabiner catch on the anchor, and without visual confirmation seems to be fully engaged to the anchor point.
- D. To each other.
- E. Directly to webbing or rope lanyard or tie-back (unless the manufacturer's instructions for both the lanyard and connector specifically allows such a connection).
- F. To any object which is shaped or dimensioned such that the snap hook or carabiner will not close and lock, or that roll-out could occur.
- G. In a manner that does not allow the connector to align properly while under load.

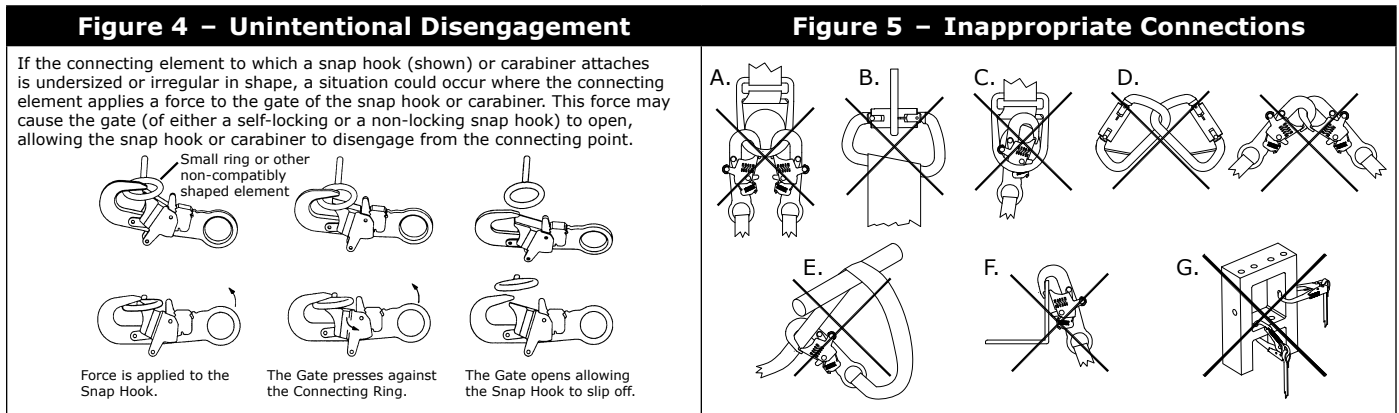

3.0 INSTALLATION

3.1 PLANNING: Plan your fall protection system before starting your work. Account for all factors that may affect your safety before, during, and after a fall. Consider all requirements and limitations defined in Section 2.

IMPORTANT: In most applications, the Nano-Lok SRL can be connected to the anchorage or the harness Dorsal location. Either orientation is allowed; except as noted in Section 4.7.

3.2 ANCHORAGE: Figure 6 illustrates typical SRL anchorage connections. Select an anchorage location with minimal free fall and swing fall hazards (see Section 2). Select a rigid anchorage point capable of sustaining the static loads defined in Section 2.2. Where anchoring overhead is not feasible, Nano-Lok SRLs may be secured to an anchorage point below the level of the user's Dorsal D-Ring. For users up to 310 lbs, (141 kg) the anchorage point must not be more than 3 ft (1 m) below the Dorsal D-Ring. For users exceeding 310 lbs. (141 kg), up to 420 lbs (191 kg), the anchorage point must not be more than 2 ft. (0.6 m) below the Dorsal D-Ring.

3.3 CAB MOUNTING: Cab Mount Nano-Lok SRL models are designed to be mounted overhead in the cab of an Order Picker or similar equipment (see Figure 1). They must be used with a Full Body Harness as part of a complete fall arrest system. Figure 7 illustrates installation of the Cab Mount SRL. Select anchorage capable of sustaining the loads defined in Section 2.2 and attach the Nano-Lok SRL as follows:

1. Detach the Attachment Handle (A) from the SRL by removing the Lock Nut (D) and Bolt (C).
2. Position the Attachment Handle (A) over the anchorage or through the anchorage point.
3. With the Spacers (B) inserted securely in each side of the SRL's Swivel Eye, position the SRL between the forks of the Attachment Handle (A) so the holes in the Handle Spacers (B) align with the holes in the Attachment Handle.
4. Insert the Bolt (C) through the Attachment Handle (A), Spacers (B), and SRL Swivel Eye.
5. Thread the Lock Nut (D) onto the Bolt (C) and tighten securely. Do not overtighten.

IMPORTANT: It is recommended that this equipment be installed under the supervision of a qualified person, as defined by OSHA 1910.66, Appendix C.

Figure 6 – Anchorage Connections

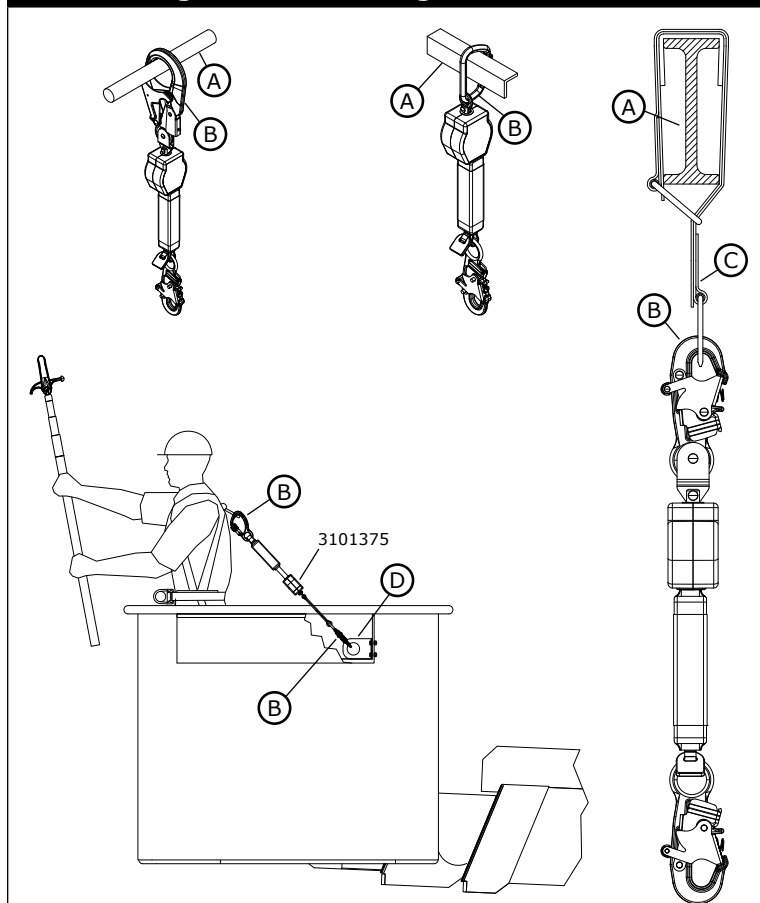
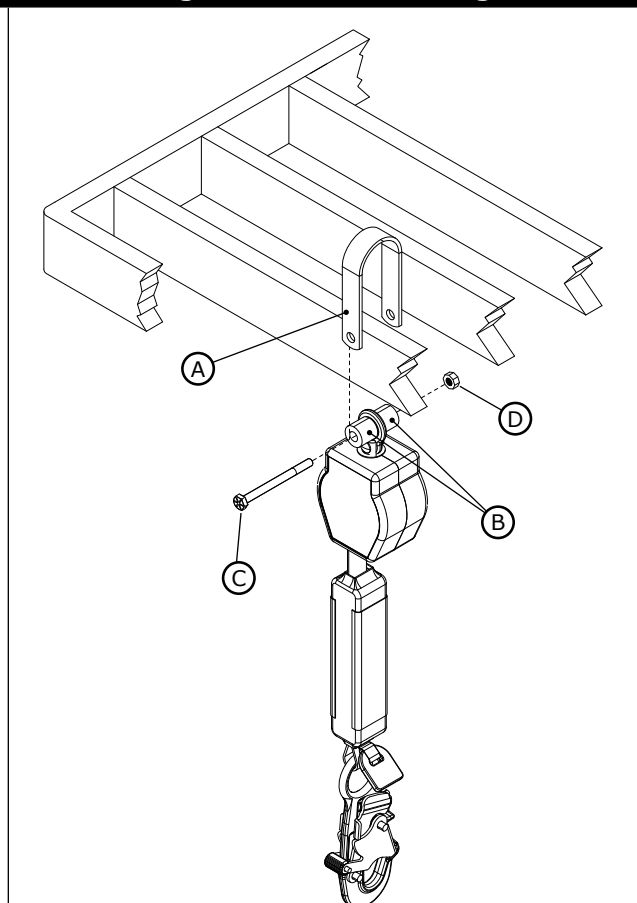

Figure 7 – Cab Mounting



A - Anchorage B - Connector C - Tie-Off Adapter D - Anchorage Point

A - Attachment Handle B - Spacers C - Bolt D - Lock Nut

3.4 HARNESS MOUNTING: Some Nano-Lok SRL models include a Single Leg or Twin SRL Harness Interface for mounting the SRL(s) on a Full Body Harness just below the Dorsal D-Ring (see Figure 8 and Figure 9):

- Single SRL Harness Interface:** Where worker mobility is critical, a Single SRL Harness Interface can be used to mount the Nano-Lok SRL on the back of a Full Body Harness just below the Dorsal D-Ring (see Figure 8). The worker can then connect to varied anchorage points located throughout the site with the Lanyard End of the SRL without repeatedly re-installing the SRL. To mount the Nano-Lok SRL on a Full Body Harness with the Single SRL Harness Interface:

- Loosen the Harness Webbing:** Pull out on the Web Straps (A) where they pass through the bottom of the Dorsal D-Ring (B) until there is sufficient space to slide the Single Leg Interface between the Web Straps and Back Pad.
- Open the Harness Interface:** Push down on the Locking Buttons (C) simultaneously and slide the Locking Pin (D) out.
- Position the Harness Interface around the Web Straps:** With the Locking Buttons (C) facing out and Gate facing up, insert the Nose End of the Harness Interface (E) behind the Web Straps (A). Rotate the Harness Interface behind the Web Straps until the Harness Interface surrounds the the Web Straps. Pull the Web Straps back through the Dorsal D-Ring and Back Pad to secure the Harness Interface.
- Attach the Nano-Lok SRL to the Harness Interface:** Slide the Swivel Eye on the SRL (F) over the Harness Interface's Locking Pin (D) and then push in the Locking Pin until it locks into place in the opposite end of the Harness Interface.

WARNING: The Red Band on the knob end of the Harness Interface Locking Pin will be exposed if the Harness Interface is unlocked. To avoid accidental release of the connection, always make sure the Harness Interface is locked before using the Harness and attached Nano-Lok SRL. Failure to do so could result in injury or death.

NOTE: It is also acceptable to connect the Nano-Lok SRL to the Harness Dorsal D-Ring with a Carabiner or Snaphook.

Figure 8 – Single SRL Harness Interface

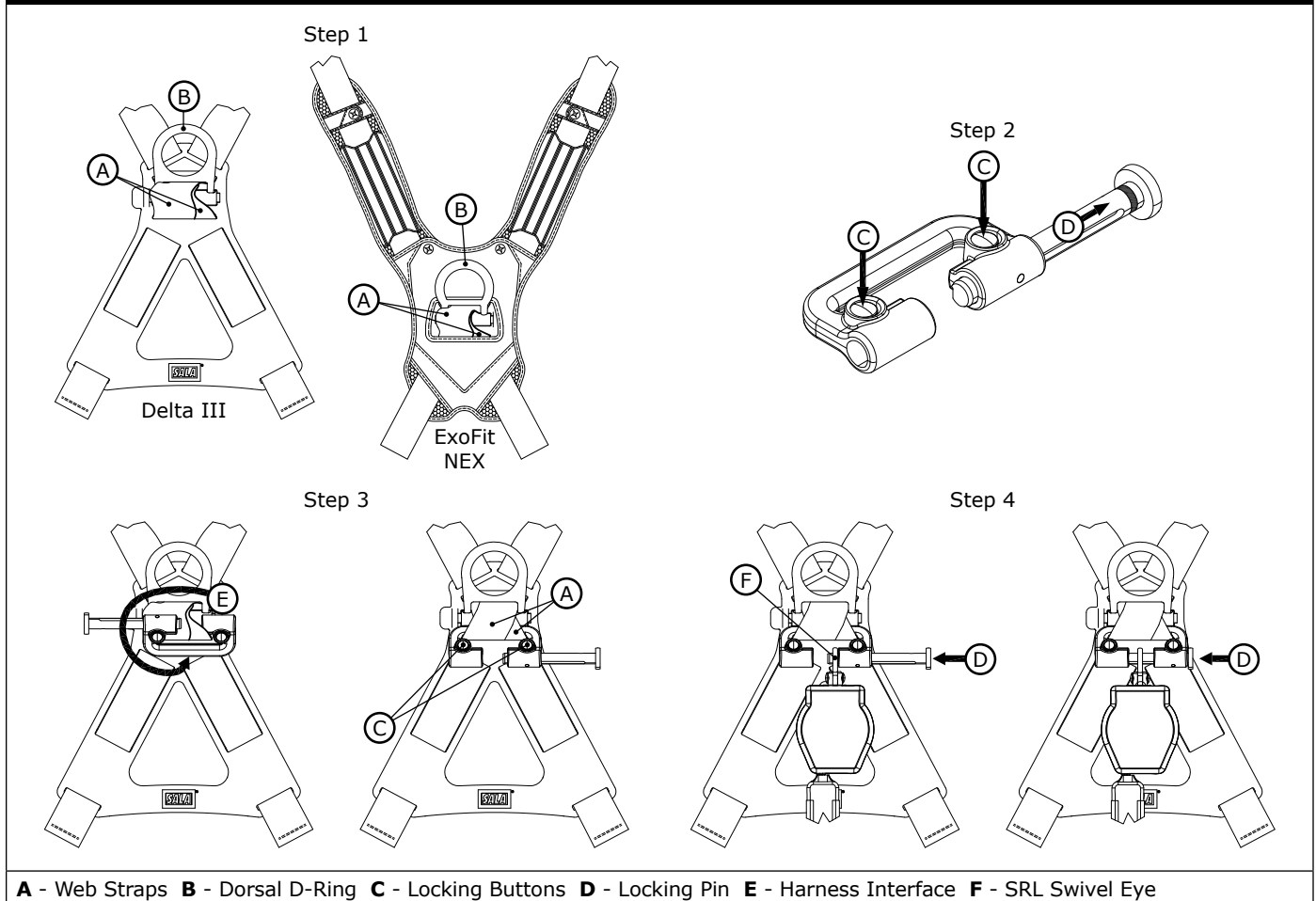

- **Twin SRL Harness Interface:** In climbing applications where 100% tie-off is required, the Twin SRL Harness Interface can be used to mount two Nano-Lok SRLs side-by-side on the back of a Full Body Harness just below the Dorsal D-Ring (see Figure 9). To mount two Nano-Lok SRLs on a Full Body Harness with the Twin SRL Harness Interface:
 1. **Loosen the Harness Webbing:** Pull out on the Web Straps (A) where they pass through the bottom of the Dorsal D-Ring (B) until there is sufficient space to slide the Twin Leg Interface between the Web Straps and D-Ring Pad.
 2. **Open the Harness Interface:** Push up on the Connector Insert (C) to unsnap the Clamps (D) from the Connector and then swing the Connector Insert up to unlock the Gate. Push the Gate (E) inward to open the Connector.
 3. **Thread the first Nano-Lok SRL onto the Harness Interface:** Insert the Nose of the Connector (F) through the Swivel Eye (G) on the SRL and then rotate the SRL around to the Gate End of the Connector (H). The Gate can be rotated toward the Nose to allow clearance for the Swivel Eye between the Gate and Spine of the Connector.
 4. **Position the Harness Interface around the Web Straps:** With the Gate facing up, insert the Nose of the Connector (F) behind the Web Straps (A). Rotate the Connector behind the Web Straps until the Connector surrounds the the Web Straps.
 5. **Add the second Nano-Lok SRL on the Harness Interface:** Slide the SRL's Swivel Eye (G) over the Nose of the Connector (F) and position the SRL Swivel Eye in the Nose End of the Connector (I). Swing the Gate (E) closed.
 6. **Close the Harness Interface:** Rotate the Connector Insert (C) forward so the Clamps (D) secure on the Connector. When properly closed, the Web Straps should pass through the Webbing Slot (J) at the top of the Connector Insert and the SRL Swivel Eyes should be secured in the Recesses (K) on either side of the Connector Insert. Once the Harness Interface is closed, pull the Web Straps (A) back through the Dorsal D-Ring and D-Ring Pad to eliminate slack in the webbing and secure the Connector between the Web Straps and D-Ring Pad.

NOTE: Older ExoFit harnesses may require a different Twin SRL Harness Interface. See Appendix A.

4.0 USE

WARNING: Do not alter or intentionally misuse this equipment. Consult Capital Safety when using this equipment in combination with components or subsystems other than those described in this manual. Some subsystem and component combinations may interfere with the operation of this equipment. Use caution when using this equipment around moving machinery, electrical hazards, chemical hazards, sharp edges, or overhead materials that may fall onto the lifeline. Do not loop the lifeline around small structural members. Failure to heed this warning may result in equipment malfunction, serious injury, or death.

WARNING: Consult your doctor if there is reason to doubt your fitness to safely absorb the shock from a fall arrest. Age and fitness seriously affect a worker's ability to withstand falls. Pregnant women or minors must not use DBI-SALA self retracting lifelines.

- 4.1 **BEFORE EACH USE:** Before each use of this fall protection equipment carefully inspect it to assure it is in good working condition. Check for worn or damaged parts. Ensure all bolts are present and secure. Check that the lifeline is retracting properly by pulling out the line and allowing it to slowly retract. If there is any hesitation in retraction, remove the SRL from service, mark "UNUSABLE", and dispose of in the recommended manner (see "Section 5.5 - Disposal"). Inspect the lifeline for cuts, frays, burns, crushing and corrosion. Check locking action by pulling sharply on the line. See Section 5 for inspection details.
- 4.2 **AFTER A FALL:** Any equipment which has been subjected to the forces of arresting a fall or exhibits damage consistent with the effect of fall arrest forces as described in Section 5, must be removed from service immediately, marked "UNUSABLE", and disposed of in the recommended manner (see "Section 5.5 - Disposal").
- 4.3 **BODY SUPPORT:** A full body harness must be worn when using Nano-Lok SRLs. For general fall protection use, connect to the back (dorsal) D-ring. For situations such as ladder climbing, it may be useful to connect to the front of the harness above the worker's center of gravity. This is acceptable provided potential free fall is less than 2 ft. (61 cm) and footing can be easily regained.

IMPORTANT: Do not use a body belt for free fall applications. See OSHA 1926.502 for guidelines.

- 4.4 **MAKING CONNECTIONS:** Figure 10 illustrates harness and anchorage connections for Nano-Lok SRL Fall Arrest Systems. When using a hook to make a connection, ensure roll-out cannot occur (see Figure 4). Do not use hooks or connectors that will not completely close over the attachment object. Do not use non-locking snap hooks. The anchorage must meet the anchorage strength requirements stated in section 2.2. Follow the manufacturer's instructions supplied with each system component.

Figure 9 – Twin SRL Harness Interface

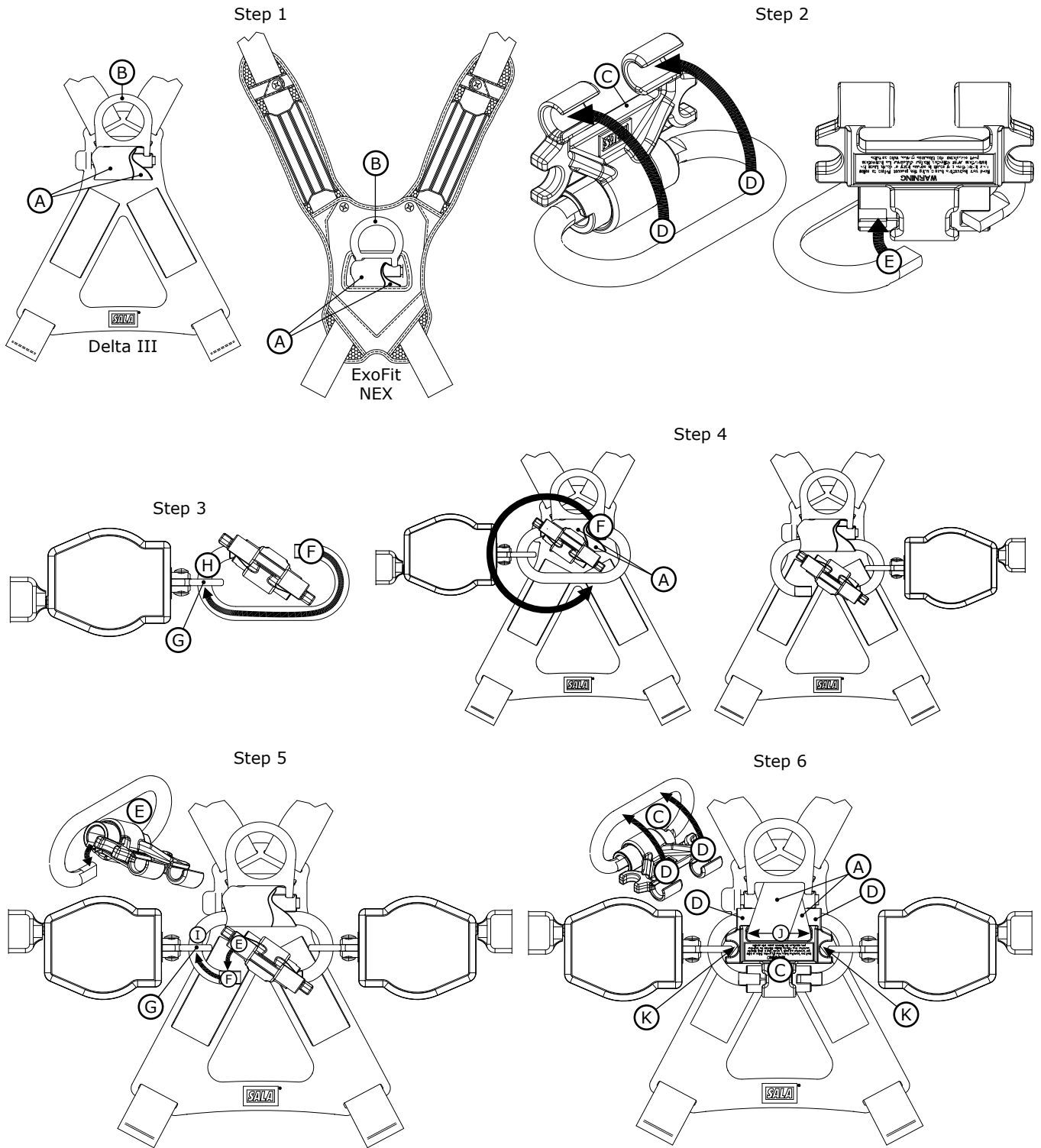

A - Web Straps **B** - Dorsal D-Ring **C** - Connector Insert **D** - Clamps, Connector Insert **E** - Gate, Connector **F** - Nose, Connector
G - Swivel Eye, SRL **H** - Gate End, Connector **I** - Nose End, Connector **J** - Webbing Slot, Connector Insert
K - Swivel Eye Recesses, Connector Insert

Figure 10 – Nano-Lok SRL System Connections

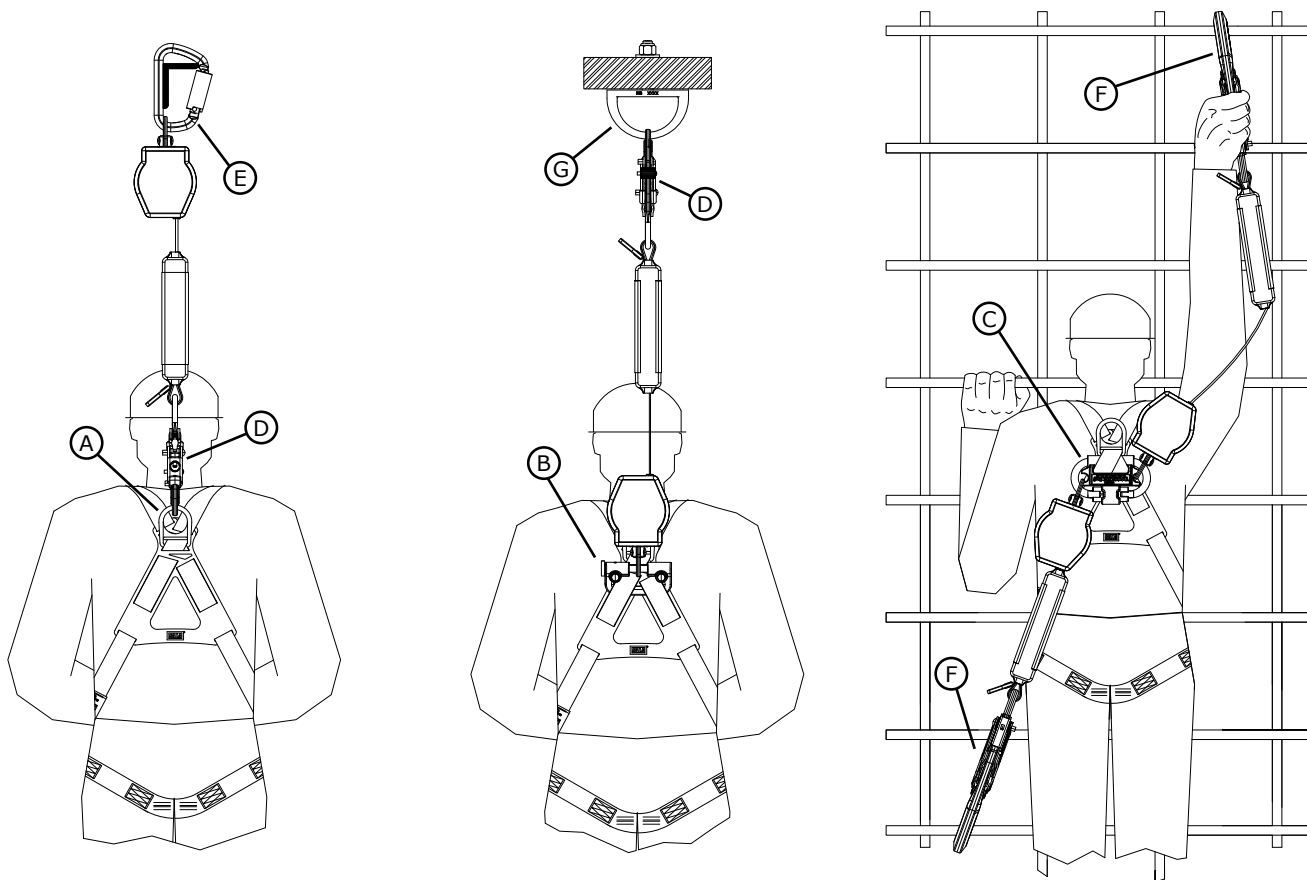

A - Dorsal D-Ring **B** - Single SRL Harness Interface **C** - Twin SRL Harness Interface **D** - Snap Hook **E** - Carabiner
F - Rebar Hook **G** - Anchorage Point

4.5 OPERATION: Prior to use, inspect the SRL as described in section 5.0. Figure 10 shows system connections for typical Nano-Lok SRL applications. Connect the Nano-Lok SRL to a suitable anchorage or mount the SRL on the back of a Full Body Harness per the instruction in Section 3. On anchorage connected SRLs, connect the Hook (D) or Carabiner on the Load Indicator to the Dorsal D-Ring (A) on the Full Body Harness. On harness mounted SRLs, connect the Hook (D) or Carabiner to a suitable anchorage. Ensure connections are compatible in size, shape, and strength. Ensure hooks are fully closed and locked. Once attached, the worker is free to move about within the recommended working area at normal speeds. If a fall occurs the SRL will lock and arrest the fall. Upon rescue, remove the SRL from use. When working with an SRL, always allow the lifeline to recoil back into the device under control.

WARNING: Do not tie or knot the lifeline. Avoid lifeline contact with sharp or abrasive surfaces. Inspect the lifeline frequently for cuts, fraying, burns, or signs of chemical damage. Dirt, contaminants, and water can lower dielectric properties of the lifeline. Use caution near power lines.

4.6 TWIN LEG INTERFACE 100% TIE-OFF: When two Nano-Lok SRLs are mounted side-by-side on the back of a Full Body Harness, the SRL Fall Arrest System can be used for continuous fall protection (100 % tie-off) while ascending, descending, or moving laterally (see Figure 11). With the Lanyard Leg of one SRL attached to an anchorage point, the worker can move to a new location, attach the unused Lanyard Leg of the other SRL to another anchorage point, and then disconnect from the original anchorage point. The sequence is repeated until the worker reaches the desired location. Considerations for twin leg 100% tie-off applications include the following:

- Connection of each Lanyard Leg to a separate anchorage point is acceptable (Figure 11).
- Never connect more than one person at a time to the Twin-Leg system (Figure 12).
- Do not allow the Lanyards to become tangled or twisted together as this may prevent them from retracting.
- Do not allow any lanyard to pass under arms or between legs during use.

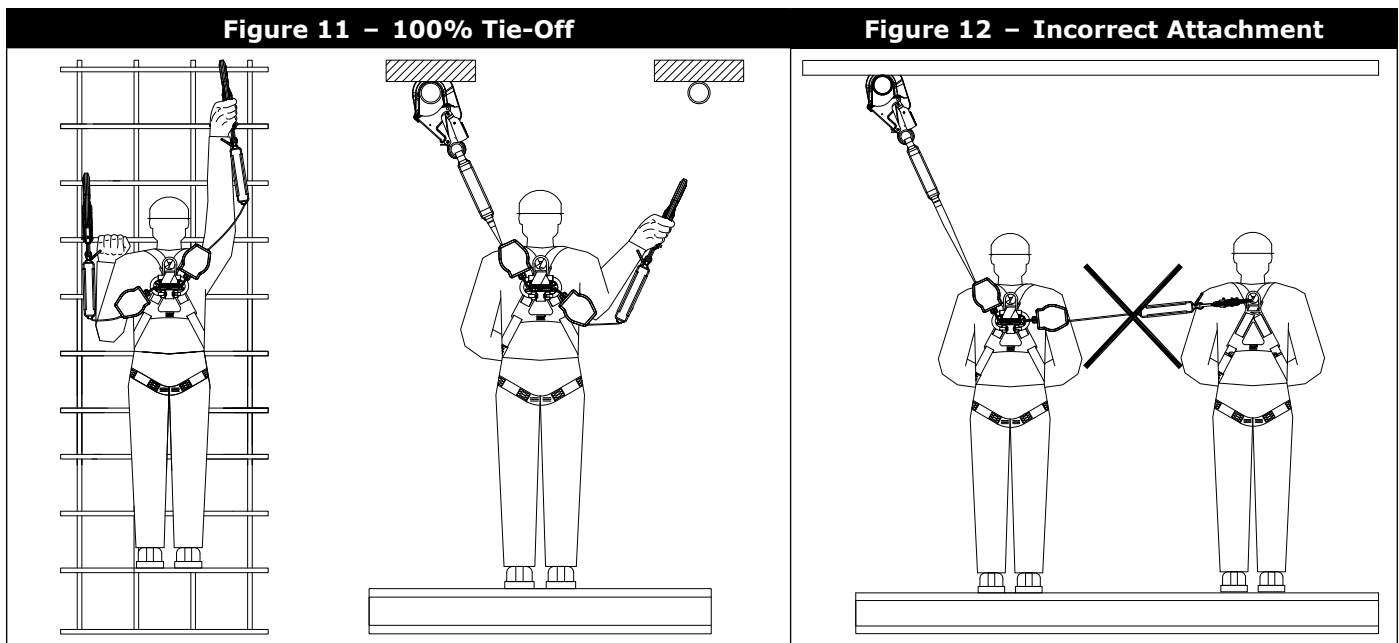

4.7 AERIAL WORK PLATFORMS: Use of the Nano-Lok SRL on aerial work platforms is permissible, provided the following criteria are met:

1. Nano-Lok SRLs generally will not restrain workers from falling out of aerial work platforms or elevated working surfaces. To restrain users from falling out of aerial work platforms, Positioning Lanyards of sufficiently short lengths should be used.
2. Aerial work platforms must have guardrails or gates at all accessible edges along their perimeter unless anchorages for the Nano-Lok SRLs are located overhead. The edges on the top rails of all guardrails and gates over which the user might fall must have a minimum radius of 1/8 in. (0.3 cm).
3. Anchorages of appropriate strength and compatibility must always be used for securing Nano-Lok SRLs (see Section 2).
4. Swing fall hazards may exist, especially when working near corners or out away from anchorage points. Added fall clearance is needed where the potential for swing fall exists (see Figure 3).
5. All sharp edges which the Nano-Lok SRL's lifeline may contact during a fall must be eliminated or covered over. All edges the SRL lifeline may contact in a fall must be smooth with an edge radius of 1/8 in. (0.3 cm) or greater. Potential pinch points between adjacent surfaces where the lifeline may catch during a fall must be eliminated.

4.8 HORIZONTAL SYSTEMS: In applications where the Nano-Lok SRL is used in conjunction with a horizontal system (i.e. Horizontal Lifeline, Horizontal I-Beams Trolley), the SRL and horizontal system components must be compatible. Horizontal systems must be designed and installed under the supervision of a qualified engineer. Consult the horizontal system equipment manufacturer's instructions for details.

5.0 INSPECTION

5.1 i-Safe™ RFID TAG: The Nano-Lok SRL includes an i-Safe™ Radio Frequency Identification (RFID) tag. The RFID tag can be used in conjunction with the i-Safe handheld reading device to simplify inspection and inventory control and provide records for your fall protection equipment. If you are a first-time user, contact a Capital Safety Customer Service representative (see back cover); or if you have already registered, go to isafe.capitalsafety.com. Follow the instructions provided with your i-Safe handheld reader or software to transfer your data to your database.

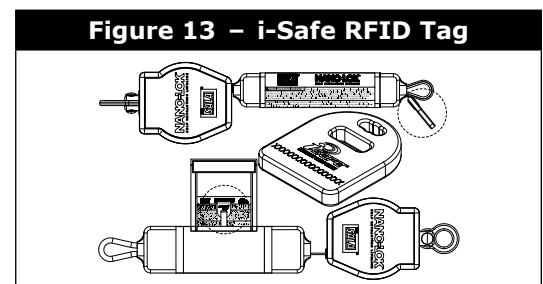

5.2 INSPECTION FREQUENCY: The Nano-Lok SRL must be inspected at the intervals defined in "Section 2.5 - Inspection Frequency". Inspection procedures are described in the "Inspection Checklist" (Table 2).

5.3 UNSAFE OR DEFECTIVE CONDITIONS: If inspection reveals an unsafe or defective condition, If inspection reveals an unsafe condition, remove the SRL from service, mark "UNUSABLE", and dispose of in the recommended manner (see "Section 5.5 - Disposal").

- 5.4 PRODUCT LIFE:** The functional life of Nano-Lok SRLs is determined by work conditions and maintenance. As long as the SRL passes inspection criteria, it may remain in service.
- 5.5 DISPOSAL:** Dispose of the Nano-Lok SRL if it has been subjected to fall force or inspection reveals an unsafe or defective condition. Before disposing of the SRL, cut the Load Indicator off of the Web Lanyard or otherwise disable the SRL to eliminate the possibility of inadvertent reuse.

6.0 MAINTENANCE, SERVICING, AND STORAGE

6.1 CLEANING: Cleaning procedures for the Nano-Lok SRL are as follows:

- Periodically clean the exterior of the SRL using water and a mild soap solution. Position the SRL so excess water can drain out. Clean labels as required.
- Clean the Web Lifeline with water and mild soap solution. Rinse and thoroughly air dry. Do not force dry with heat. The lifeline should be dry before allowing it to retract into the housing. An excessive buildup of dirt, paint, etc. may prevent the lifeline from fully retracting back into the housing causing a potential free fall hazard.

IMPORTANT: If the lifeline contacts acids or other caustic chemicals, remove the SRL from service and wash with water and a mild soap solution. Inspect the SRL per Table 2 before returning to service.

- 6.2 SERVICE:** Nano-Lok SRLs are not repairable. If the SRL has been subjected to fall force or inspection reveals an unsafe or defective condition, remove the SRL from service, mark "UNUSABLE", and dispose of in the recommended manner (see "Section 5.5 - Disposal").
- 6.3 STORAGE:** Store Nano-Lok SRLs in a cool, dry, clean environment out of direct sunlight. Avoid areas where chemical vapors may exist. Thoroughly inspect the SRL after any period of extended storage.

7.0 SPECIFICATIONS

7.1 PERFORMANCE: Your Nano-Lok SRL has been tested and certified to the performance requirements of the standard(s) identified on the cover of this instruction manual. See "Section 2.0 - Limitations & Requirements" for performance specifications.

7.2 MATERIALS: Material specifications for the Nano-Lok SRL are as follows:

Housing:	Nylon, UV Resistant	Motor Spring:	Stainless Steel
Drum:	Nylon, Type 6/6	Swivel:	Zinc Plated Steel
Fasteners:	Zinc Plated Steel Screws; Stainless Steel Rivets	Lifeline:	Dynema Polyester Web
		Arc Flash Models:	Kevlar Web
Locking Pawls:	Stainless Steel	Load Indicator	Cover: Denier Textured Nylon Stitching: Polyester or Nylon Thread Web: Polyester
Main Shaft:	Stainless Steel		
End Connectors:	See Figure 18 for End Connector options and their respective material specifications.		

- 7.3 DIMENSIONS:** Figure 18 lists Nano-Lok SRL dimensions. Average working range for the Nano-Lok SRL is 6 ft. (1.8 m), but will vary slightly with length differences in the various End Connector options. Retracted and Extended length values in Figure 18 are approximations based on the total length of the fully retracted/extended SRL and the applicable End Connectors.
- 7.4 LABELING:** Figure 19 illustrates Nano-Lok SRL labeling. All labels on the SRL must be present and fully legible.

Table 2 – Inspection Checklist

Component:	Inspection:	Pass	Fail
SRL (Figure 14)	Inspect for loose fasteners and bent or damaged parts.	<input type="checkbox"/>	<input type="checkbox"/>
	Inspect the Housing (A) for distortion, cracks, or other damage.	<input type="checkbox"/>	<input type="checkbox"/>
	Inspect the Swivel (B) and Swivel Eye (C) or Integral Connector (D) for distortion, cracks, or other damage. The Swivel should be attached securely to the SRL, but should pivot freely. The Swivel Eye or Integral Connector should rotate freely in the Swivel.	<input type="checkbox"/>	<input type="checkbox"/>
	The Web Lifeline (E) should pull out and retract fully without hesitation or creating a slack line condition.	<input type="checkbox"/>	<input type="checkbox"/>
	Ensure the SRL locks up when the Lifeline is jerked sharply. Lockup should be positive with no slipping.	<input type="checkbox"/>	<input type="checkbox"/>
	All labels must be present and fully legible (see Figure 19).	<input type="checkbox"/>	<input type="checkbox"/>
	Inspect the entire SRL for signs of corrosion.	<input type="checkbox"/>	<input type="checkbox"/>
Web Lifeline (Figure 15)	Inspect the web lifeline for concentrated wear, frayed strands, broken yarn, burns, cuts, and abrasions. The lifeline must be free of knots throughout its length. Inspect for excessive soiling, paint build-up, and rust staining. Inspect for chemical or heat damage indicated by brown, discolored, or brittle areas. Inspect for ultraviolet damage indicated by discoloration and the presence of splinters and slivers on the lifeline surface.	<input type="checkbox"/>	<input type="checkbox"/>
Load Indicator (Figure 16)	Inspect the Load Indicator to determine if it has been activated. There should be no evidence of elongation and the cover should be secure and free of tears or other damage.	<input type="checkbox"/>	<input type="checkbox"/>
End Connectors (Figure 17)	Figure 1 identifies the End Connectors that should be included on your Nano-Lok SRL model. Inspect all Snap Hooks, Carabiners, Rebar Hooks, Interfaces, etc. for signs of damage, corrosion, and proper working condition. Where present: Swivels (A) should rotate freely, Gates (B) should open, close, lock, and unlock properly, and Locking Buttons (C) and Locking Pins (D) should function correctly.	<input type="checkbox"/>	<input type="checkbox"/>

Figure 14 – SRL Inspection

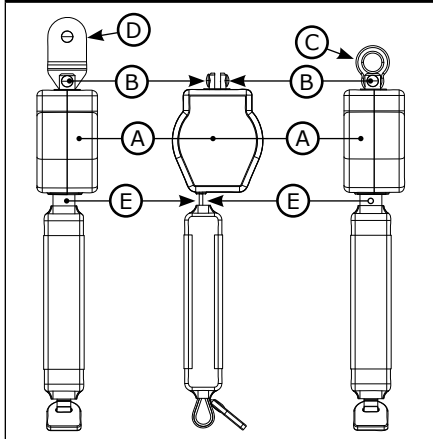

Figure 15 – Web Lifeline

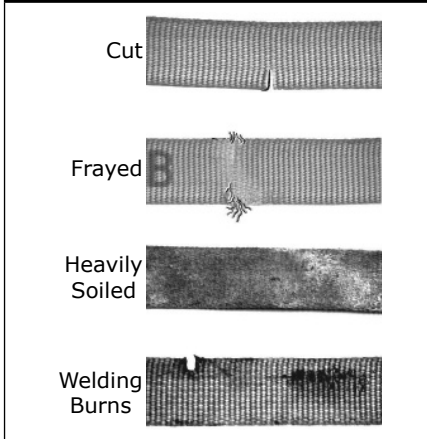

Figure 16 – Load Indicator

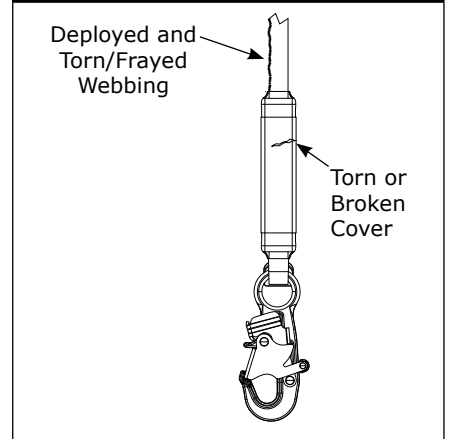

Figure 17 – End Connectors

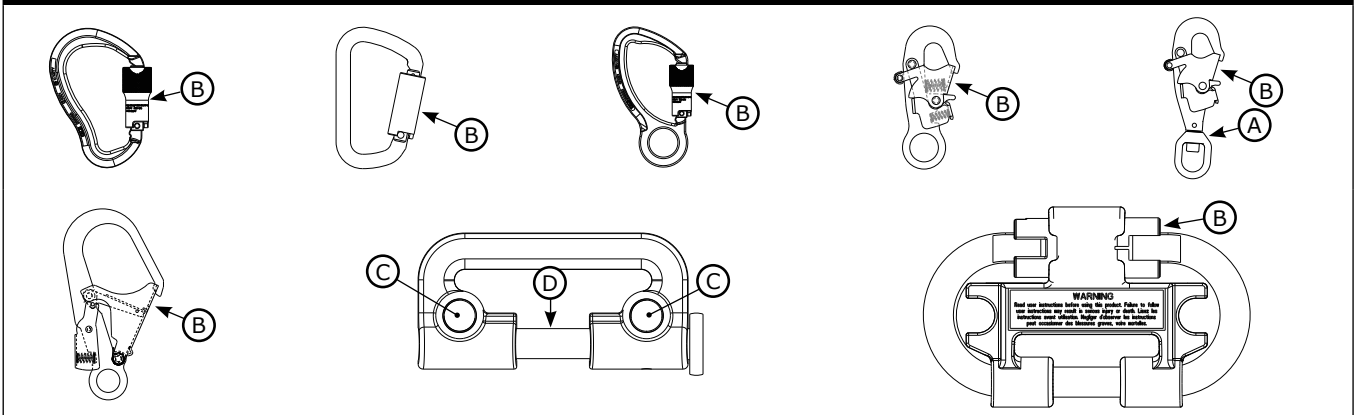
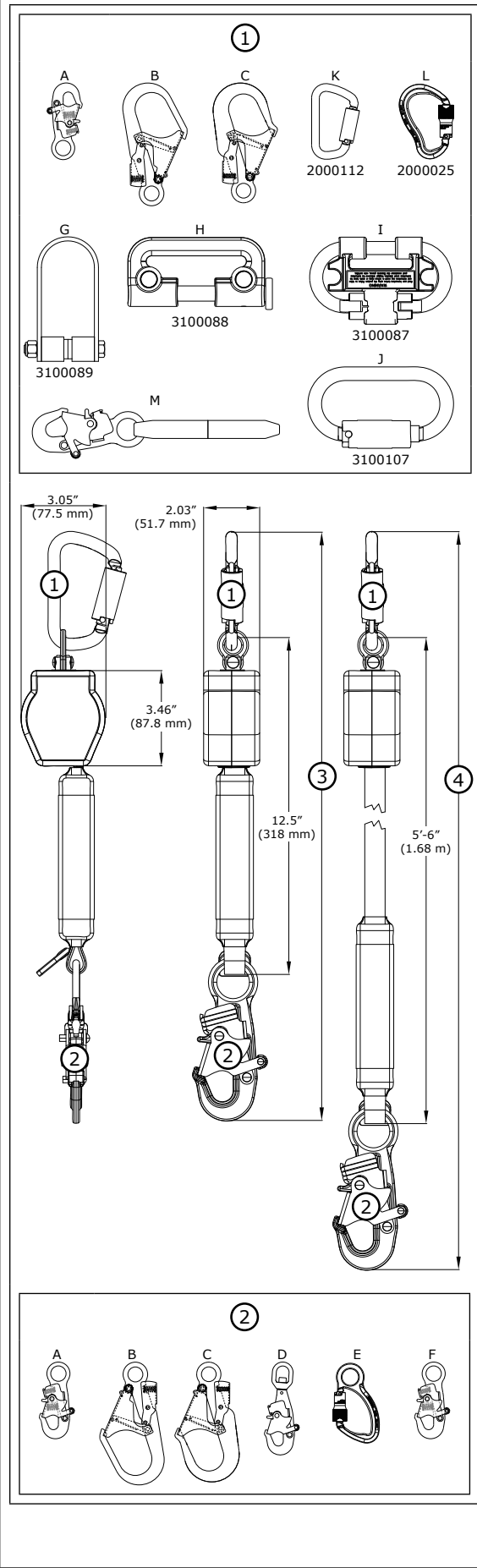

Figure 18 – Dimensions & End Connector Specifications



Model	End Connectors		Length (Retracted)		Length (Extended)	
	① Swivel	② Lanyard	③ in.	③ mm	④ ft.	④ m
3101214	L	F	22.75	577.85	6.35	1.94
3101215	K	A	21.73	551.94	6.27	1.91
3101216	K	D	22.02	559.31	6.29	1.92
3101217	K	B	24.21	614.93	6.48	1.97
3101218	A	A	22.30	566.42	6.32	1.93
3101219	A	B	24.78	629.41	6.52	1.99
3101235	L	E	22.00	558.80	6.29	1.92
3101236	L	C	24.00	609.60	6.46	1.97
3101237	C	E	26.50	673.10	6.67	2.03
3101238	C	F	25.69	652.53	6.60	2.01
3101241	B	D	21.19	538.23	6.22	1.90
3101225	H	E	19.84	503.89	6.11	1.86
3101226	H	F	20.59	522.94	6.17	1.88
3101227	H	C	21.84	554.69	6.28	1.91
3101228	H	A	18.74	475.95	6.02	1.83
3101229	H	B	21.22	538.94	6.23	1.90
3101253	H	D	19.03	483.31	6.04	1.84
3101275	I	E	20.45	519.43	6.16	1.88
3101276	I	F	21.20	538.48	6.23	1.90
3101277	I	C	22.45	570.23	6.33	1.93
3101278	I	D	19.64	498.86	6.10	1.86
3101279	I	A	19.35	491.49	6.07	1.85
3101280	I	B	21.83	554.48	6.28	1.91
3101271	J	E	20.45	519.43	6.16	1.88
3101272	J	F	21.20	538.48	6.23	1.90
3101273	J	C	22.45	570.23	6.33	1.93
3101274	J	D	19.64	498.86	6.10	1.86
3101287	J	A	19.35	491.49	6.07	1.85
3101288	J	B	21.83	554.48	6.28	1.91
3101239	G	D	20.94	531.88	6.20	1.89
3101240	G	A	20.65	524.51	6.18	1.88
3101358	M	—	24.50	622.30	6.50	1.98
3101360	H	D	19.03	483.31	6.04	1.84
3101361	H	A	18.74	475.95	6.02	1.83
3101362	H	B	21.22	538.94	6.23	1.90
3101363	H	E	19.84	503.89	6.11	1.86
3101364	H	C	21.84	554.69	6.28	1.91
3101375	M	E	30.50	774.70	7.00	2.13
3101380	I	A	19.35	491.49	6.07	1.85
3101381	I	D	19.64	498.86	6.10	1.86
3101382	I	B	21.83	554.48	6.28	1.91
3101383	I	E	20.45	519.43	6.16	1.88
3101384	I	C	22.45	570.23	6.33	1.93
3101385	K	A	21.73	551.94	6.27	1.91

① ② Connector:	Type:	Material:	Gate Opening	Gate Strength
E	Carabiner	Aluminum	3/4 in. (19 mm)	3,600 lb (16 kN)
L	Carabiner	Aluminum	3/4 in. (19 mm)	3,600 lb (16 kN)
K	Carabiner	Steel	1-3/16 in. (30 mm)	3,600 lb (16 kN)
B	Rebar Hook	Steel	2-1/2 in. (62.5 mm)	3,600 lb (16 kN)
H	Single Leg Interface	Steel		
I	Twin SRL Interface	Steel w/Nylon Insert	3/4 in. (19 mm)	3,600 lb (16 kN)
J	Twin SRL Interface (ExoFit Fixed D-Ring)	Steel	3/4 in. (19 mm)	3,600 lb (16 kN)
G	Cab Mount	Stainless Steel	1.63 in. (41.4 mm)	
C	Rebar Hook	Aluminum	2-1/4 in. (57 mm)	3,600 lb (16 kN)
A	Snap Hook	Steel	3/4 in. (19 mm)	3,600 lb (16 kN)
D	Swiveling Snap Hook	Steel	3/4 in. (19 mm)	3,600 lb (16 kN)
F	Snap Hook	Aluminum	3/4 in. (19 mm)	3,600 lb (16 kN)
M	Kevlar Web Leg with Snap Hook	Aluminum	3/4 in. (19 mm)	3,600 lb (16 kN)

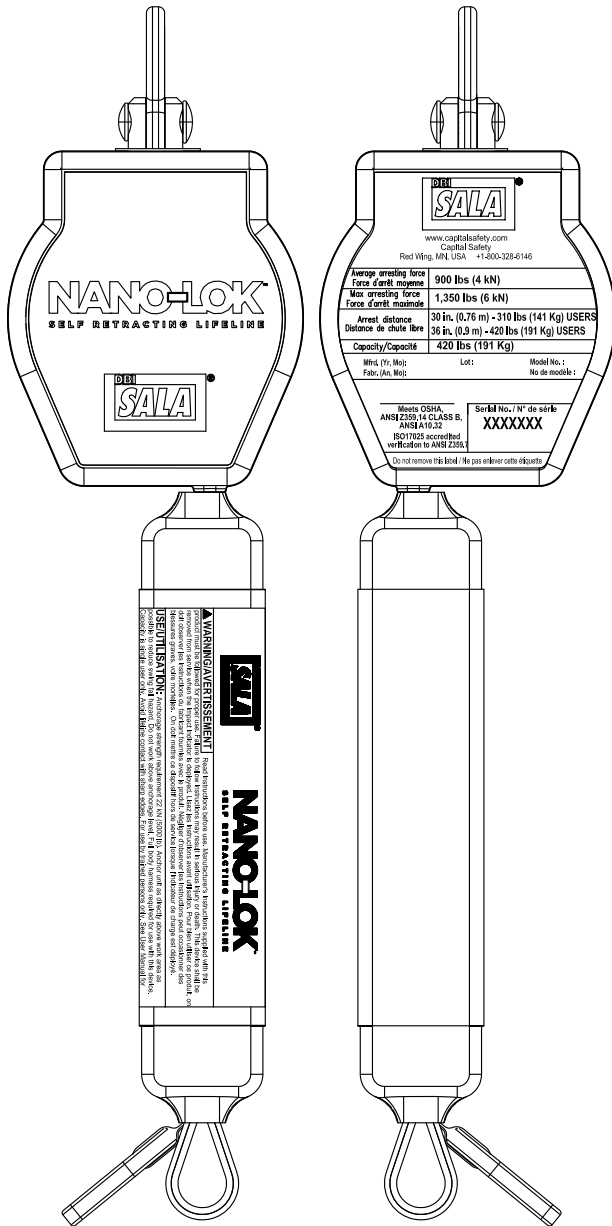

Figure 19 – Labeling





www.capitalsafety.com
Capital Safety
Red Wing, MN, USA +1-800-328-6146

Average arresting force Force d'arrêt moyenne	900 lbs (4 kN)	
Max arresting force Force d'arrêt maximale	1,350 lbs (6 kN)	
Arrest distance Distance de chute libre	30 in. (0.76 m) - 310 lbs (141 Kg) USERS 36 in. (0.9 m) - 420 lbs (191 Kg) USERS	
Capacity/Capacité	420 lbs (191 Kg)	
Mfrd. (Yr, Mo): Fabr. (An, Mo):	Lot :	Model No. : No de modèle :
Meets OSHA, ANSI Z359.14 CLASS B, ANSI A10.32 ISO17025 accredited verification to ANSI Z359.7		Serial No. / N° de série XXXXXXX
Do not remove this label / Ne pas enlever cette étiquette		

WARNING/AVERTISSEMENT Read instructions before use. Manufacturer's instructions supplied with this product must be followed for proper use. Failure to follow instructions may result in serious injury or death. This device shall be removed from service when the impact indicator is deployed. Lisez les instructions avant utilisation. Pour bien utiliser ce produit, on doit observer les Instructions du fabricant fournies avec le produit. Négliger d'observer les Instructions peut occasionner des blessures graves, voire mortelles. On doit mettre ce dispositif hors de service lorsque l'indicateur de charge est déployé.

USE/UTILISATION: Anchorage strength requirement 22 kN (5000 lb). Anchor unit as directly above work area as possible to reduce swing fall hazard. Do not work above anchorage level. Full body harness required for use with this device. Capacity is single user only. Avoid lifeline contact with sharp edges. For use by trained persons only. This unit is suitable for use with horizontal lifelines. See user manual for additional information including suitability for horizontal use. Contact Capital Safety with any questions about the proper use of this product. L'ancrage doit avoir une résistance de 22kN (5000 lb). L'ancrage doit être aussi directement que possible au-dessus de la zone de travail pour réduire le risque de chute par balancement. Ne pas travailler au-dessus du niveau de l'ancrage. On doit porter un harnais de sécurité avec ce dispositif. Capacité un seul utilisateur. Faire en sorte que la corde d'assurance n'entre pas en contact avec des arêtes vives. Doit être utilisé seulement par des personnes formées. Cette unité est conçue pour être utilisée avec des lignes de vie horizontales. Pour en savoir plus, y compris sur l'efficacité d'une utilisation horizontale, référez-vous au manuel d'utilisateur. Pour de plus amples renseignements au sujet de l'utilisation de ce produit, veuillez communiquer avec Capital Safety.

INSPECTION: Before each use, and at least monthly, inspect in accordance with the User Manual including locking function (pull sharply to test), retraction, lifeline condition, function and condition of connector, housing, and fasteners, legibility of labels, and any evidence of defects, damage or missing parts. Inspect for ruptured or torn webbing extending from load indicator cover, ruptured or torn webbing is an indicator that an impact has occurred and the unit must be removed from service. Inspection by a competent person required at least annually. See User Manual. Do not use if inspection reveals an unsafe condition. Not user repairable. Avant chaque utilisation et au moins une fois par mois, procédez à l'inspection du matériel conformément au manuel de l'utilisateur, ce qui inclut la fonction de verrouillage (tirez fermement pour la tester), le mécanisme de rétraction, l'état de la corde d'assurance, le fonctionnement et l'état du connecteur, du boîtier et des dispositifs de fixation et la lisibilité des étiquettes. Assurez-vous en outre qu'il n'y ait aucun défaut, dommage ou aucune pièce manquante. Vérifiez s'il y a une rupture ou déchirement de la sangle qui dépasse du couvercle de l'indicateur de charge. Une rupture ou un déchirement de la sangle indique qu'un impact s'est produit et qu'on doit mettre le dispositif hors de service. Une inspection par une personne compétente doit être réalisée au moins une fois par an. Reportez-vous au manuel de l'utilisateur. Si lors d'une inspection il est remarqué que l'équipement peut représenter un danger, ne l'utilisez pas. N'est pas réparable par l'utilisateur.

<p>SPECIFICATIONS: Length: 1.83 m (6 ft) Lifeline Material: Dyneema web 20mm (.787") x 1.3mm (.052")</p> <p>Free fall limit: ≤ 310lb (141kg) users = 3ft (.91m) 310lb - 420lb (141kg - 191kg) users = 2ft (.61m) limite de chute libre: ≤ 310lb (141kg) utilisateurs = 3ft (.91m) 310lb - 420lb (141kg - 191kg) utilisateurs = 2ft (.61m)</p> <p>This product is i-Safe enabled and contains an electronic tag that can be read by compatible readers - providing Inspection logs, Inventory management and other safety information. Ce produit est valide dans i-Safe et contient une rondelle d'identification électronique qui peut être lue par des lecteurs compatibles - en fournissant des registres d'inspection, de l'informations sur la gestion des stocks et d'autre information relative à la protection.</p>	<p>CARACTÉRISTIQUES: Longueur: 1,83 m (6,0 pi) Matériau de la corde d'assurance : sangle en dyneema 20 mm (0.781 pi) x 1,3 mm (0.052 pi)</p>
--	---

INSPECTION LOG RELEVÉ D'INSPECTION			
DATE	INITIAL	DATE	INITIAL

DO NOT REMOVE THIS LABEL
Ne pas enlever cette étiquette

9507329 Rev. A

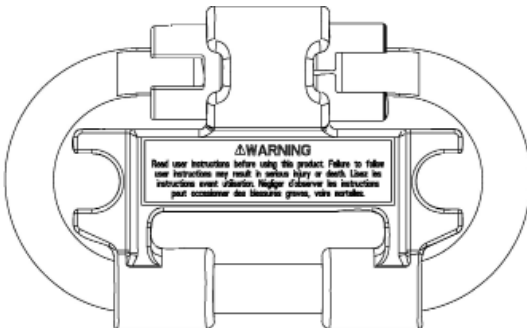



⚠ WARNING

Read user instructions before using this product. Failure to follow user instructions may result in serious injury or death. Lisez les instructions avant utilisation. Négliger d'observer les instructions peut occasionner des blessures graves, voire mortelles.

Figure 19 – Labeling

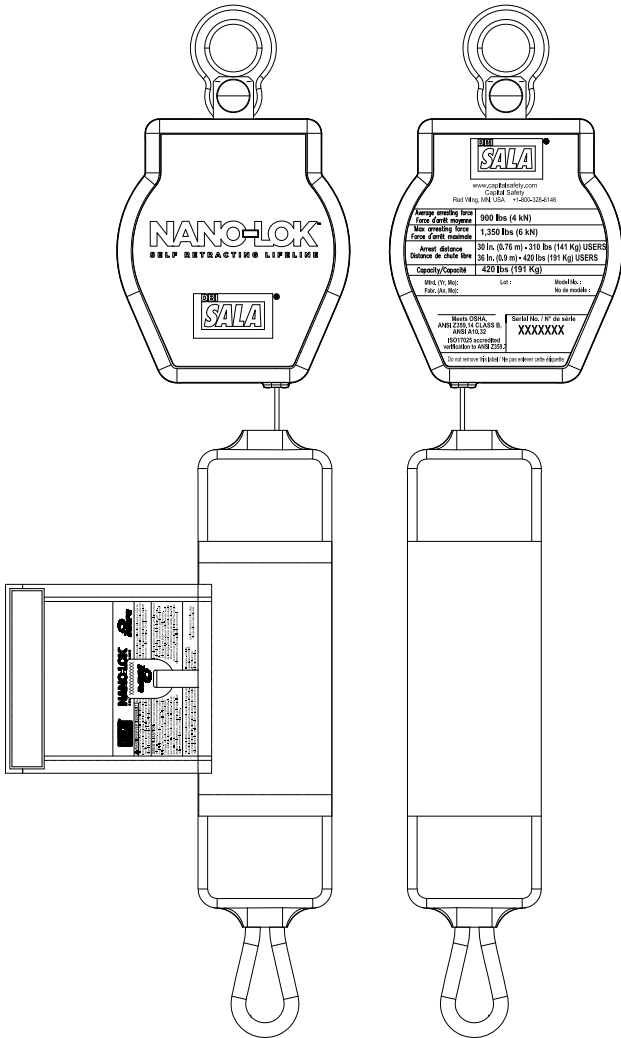
Arc Flash Models





www.capitalsafety.com
Capital Safety
Red Wing, MN, USA +1-800-328-6146

Average arresting force Force d'arrêt moyenne	900 lbs (4 kN)
Max arresting force Force d'arrêt maximale	1,350 lbs (6 kN)
Arrest distance Distance de chute libre	30 in. (0.76 m) - 310 lbs (141 Kg) USERS 36 in. (0.9 m) - 420 lbs (191 Kg) USERS
Capacity/Capacité	420 lbs (191 Kg)
Mfrd. (Yr, Mo): Fabr. (An, Mo):	Lot : Model No. : No de modèle :
Meets OSHA, ANSI Z359.14 CLASS B, ANSI A10.32 ISO17025 accredited verification to ANSI Z359.7	
Serial No. / N° de série XXXXXXX	

Do not remove this label / Ne pas enlever cette étiquette





▲ WARNING/AVERTISSEMENT Read Instructions before use. Manufacturer's Instructions supplied with this product must be followed for proper use. Failure to follow instructions may result in serious injury or death. This device shall be removed from service when the Impact Indicator is deployed. Lisez les Instructions avant utilisation. Pour bien utiliser ce produit, on doit observer les Instructions du fabricant fournies avec le produit. Négliger d'observer les Instructions peut occasionner des blessures graves, voire mortelles. On doit mettre ce dispositif hors de service lorsque l'Indicateur de charge est déployé.

USE/UTILISATION: Anchorage strength requirement 22 kN (5000 lb). Anchor unit as directly above work area as possible to reduce swing fall hazard. Do not work above anchorage level. Full body harness required for use with this device. Capacity is single user only. Avoid lifeline contact with sharp edges. For use by trained persons only. This unit is suitable for use with horizontal lifelines. See user manual for additional information including suitability for horizontal use. Contact Capital Safety with any questions about the proper use of this product. L'ancrage doit avoir une résistance de 22kN (5000 lb). L'ancrage doit être au-dessus de la zone de travail pour réduire le risque de chute par balancement. Ne pas travailler au-dessus du niveau de l'ancrage. On doit porter un harnais de sécurité avec ce produit. Capacité un seul utilisateur. Faire en sorte que la corde d'assurance n'entre pas en contact avec des arêtes vives. Doit être utilisé seulement par des personnes formées. Cette unité est conçue pour être utilisée avec des lignes de vie horizontales. Pour en savoir plus, y compris sur l'efficacité d'une utilisation horizontale, référez-vous au manuel d'utilisateur. Pour de plus amples renseignements au sujet de l'utilisation de ce produit, veuillez communiquer avec Capital Safety.

This product is i-Safe enabled and contains an electronic tag that can be read by compatible readers - providing inspection logs, Inventory management and other safety information. Ce produit est validé dans i-Safe et contient une rondelle d'identification électronique qui peut être lue par des lecteurs compatibles - en fournissant des registres d'inspection, de l'information sur la gestion des stocks et d'autre information relative à la protection.

DO NOT REMOVE THIS LABEL
Ne pas enlever cette étiquette

9507321 Rev. A

INSPECTION: Before each use, and at least monthly, inspect in accordance with the User Manual including locking function (pull sharply to test), retraction, lifeline condition, function and condition of connector, housing and fasteners, legibility of labels, and any evidence of defects, damage or missing parts. Inspect for ruptured or torn webbing extending from load indicator cover. Ruptured or torn webbing is an indicator that an impact has occurred and the unit must be removed from service. Inspection by a competent person required at least annually. See User Manual. Do not use if inspection reveals an unsafe condition. Not user repairable. Avant chaque utilisation et au moins une fois par mois, procédez à l'inspection du matériel conformément au manuel de l'utilisateur, ce qui inclut la fonction de verrouillage (tirer fermement pour la tester), le mécanisme de rétraction, l'état de la corde d'assurance, le fonctionnement et l'état du connecteur, du boîtier et des dispositifs de fixation et la lisibilité des étiquettes. Assurez-vous en outre qu'il n'y ait aucun défaut, dommage ou aucune pièce manquante. Vérifiez s'il y a une rupture ou déchirement de la sangle qui dépasse du couvercle de l'indicateur de charge. Une rupture ou un déchirement de la sangle indique qu'un impact s'est produit et qu'on doit mettre le dispositif hors de service. Une inspection par une personne compétente doit être réalisée au moins une fois par an. Reportez-vous au manuel de l'utilisateur. Si lors d'une inspection il est remarqué que l'équipement peut représenter un danger, ne l'utilisez pas. N'est pas réparable par l'utilisateur.

SPECIFICATIONS / CARACTÉRISTIQUES:
 Matériaux/Matériaux: Nylon, Polyester, Nomex, Kevlar
 Length: 1,83 m (6 ft) Longueur: 1,83 m (6,0 pi)
 Lifeline/Matériel: Kevlar web 20mm (.781") x 1.7mm (.065")
 Matériau de la corde d'assurance: sangle en Kevlar 20 mm (0,781 pi) x 1,7 mm (0,065 pi)

Free fall limit: ≤ 310lb (141kg) users = 3ft (.91m)
 310lb - 420lb (141kg - 191kg) users = 2ft (.61m)

Limite de chute libre: ≤ 310lb (141kg) utilisateurs = 3ft (.91m)
 310lb - 420lb (141kg - 191kg) utilisateurs = 2ft (.61m)

Product Compliance / la conformité des produits: ASTM F887-11
 DO NOT REMOVE THIS LABEL / Ne pas enlever cette étiquette

9507320 Rev. B

INSPECTION LOG RELEVÉ D'INSPECTION			
DATE	INITIAL	DATE	INITIAL

APPENDIX A - TWIN SRL FIXED D-RING HARNESS INTERFACE

Older ExoFit Full Body Harnesses with a Fixed D-Ring require a special Twin SRL Harness Interface to mount two Nano-Lok SRLs on the back of the harness just below the Dorsal D-Ring. Specific Twin Leg Nano-Lok SRL models are available for installation on ExoFit Fixed D-Ring harnesses (see Figure 20).

Figure 20 – Twin Leg Harness Mount Models for ExoFit Fixed D-Ring Harnesses

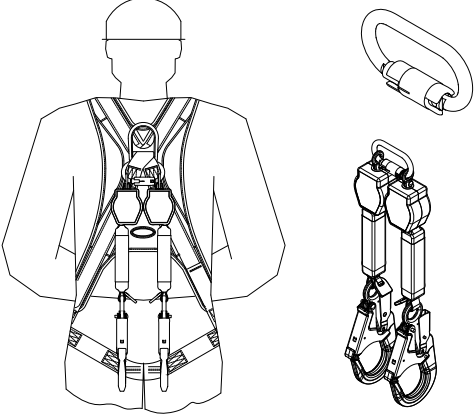
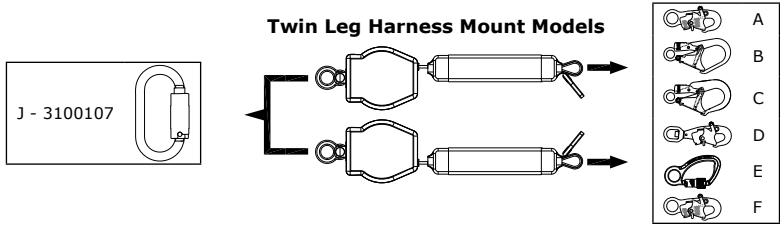
			J - 3100107 Twin SRL Fixed D-Ring Harness Interface		A - Steel Snap Hook	B - Steel Rebar Hook	C - Aluminum Rebar Hook	D - Steel Swiveling Snap Hook	E - Aluminum Carabiner (captive eye)	F - Aluminum Snap hook
Swivel End	Lanyard End	Model	Swivel End	Lanyard End						
			3101271	1					2	
			3101272	1						2
			3101273	1			2			
			3101274	1				2		
			3101287	1	2					
			3101288	1		2				

1.0 HARNESS MOUNTING: To mount two Nano-Lok SRLs on an ExoFit Full Body Harness with the Twin SRL Fixed D-Ring Harness Interface (Figure 21):

- 1. Loosen the Harness Webbing:** Pull out on the Web Straps (A) where they pass through the bottom of the Dorsal D-Ring (B) until there is sufficient space to insert the Twin Leg Interface between the Web Straps and Back Pad.
- 2. Open the Harness Interface:** With the Twin Leg Interface orientated as illustrated in Figure 2 - Step 2, push the Locking Sleeve (C) to the right and then turn clockwise to unlock the Gate (D). Swing the Gate (D) down to open.
- 3. Thread the first Nano-Lok SRL onto the Harness Interface:** Insert the Nose of the Connector (E) through the Swivel Eye (F) on the SRL and then rotate the SRL around to the Gate End of the Connector (G). The Gate can be closed to allow clearance for the Swivel Eye between the Gate and Spine of the Connector.
- 4. Position the Harness Interface around the Web Straps:** Insert the Nose of the Connector (E) behind the Web Straps (A). Rotate the Connector behind the Web Straps until the Connector surrounds the Web Straps.
- 5. Add the second Nano-Lok SRL on the Harness Interface:** Slide the SRL's Swivel Eye (F) over the Nose of the Connector (E) and position the SRL Swivel Eye in the Nose End of the Connector.
- 6. Close the Harness Interface:** Allow the Gate (D) to swing closed and the Locking Sleeve (C) to rotate back to locked position. Once the Harness Interface is closed, pull the Web Straps (A) back through the Dorsal D-Ring to eliminate slack in the webbing and secure the Harness Interface between the Web Straps and Back Pad.

Figure 21 – Twin Leg Exofit Harness Interface

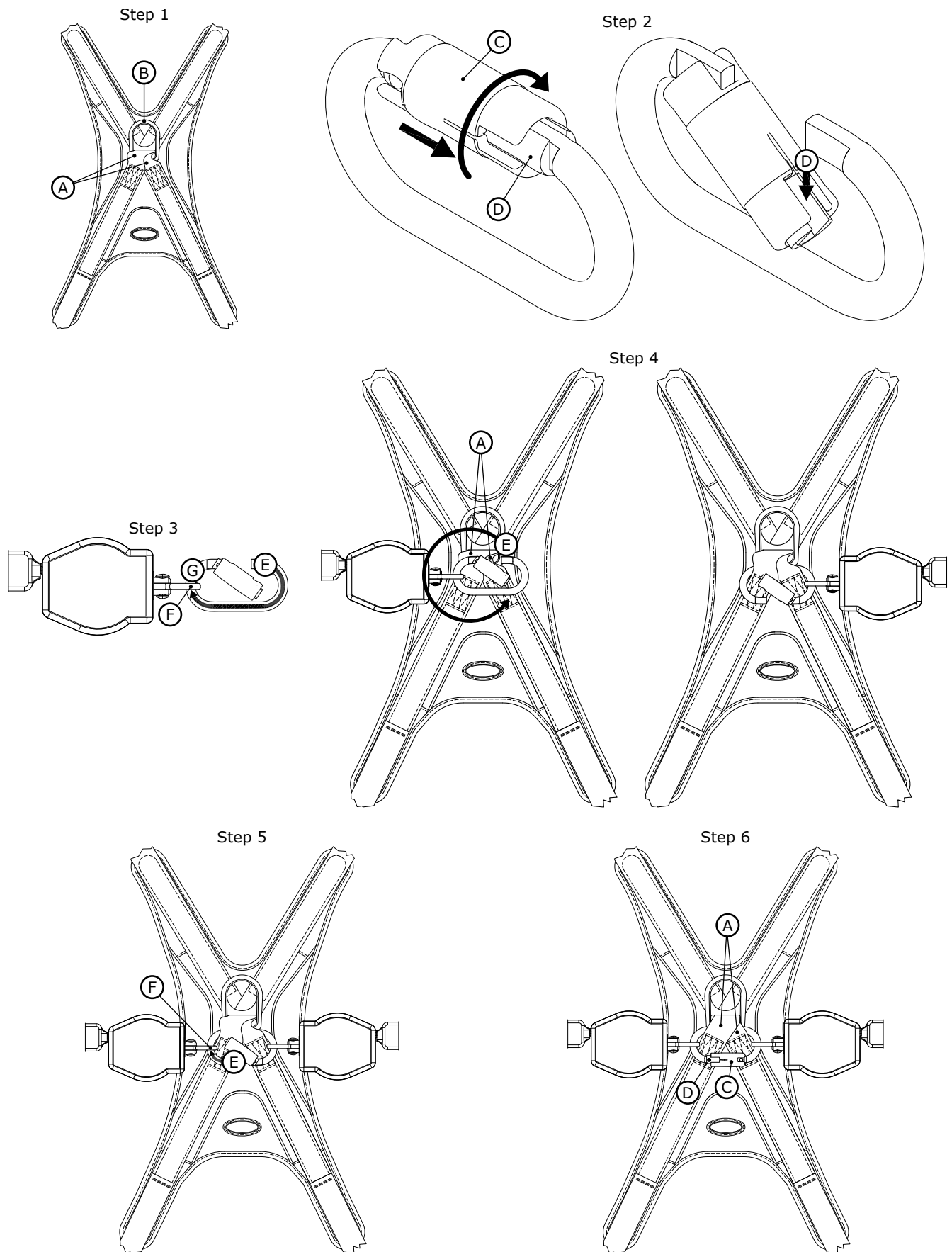

A - Web Straps B - Dorsal D-Ring C - Locking Sleeve, Connector D - Gate, Connector E - Nose, Connector F - Swivel Eye, SRL

LIMITED LIFETIME WARRANTY

Warranty to End User: D B Industries, Inc., dba CAPITAL SAFETY USA ("CAPITAL SAFETY") warrants to the original end user ("End User") that its products are free from defects in materials and workmanship under normal use and service. This warranty extends for the lifetime of the product from the date the product is purchased by the End User, in new and unused condition, from a CAPITAL SAFETY authorized distributor. CAPITAL SAFETY'S entire liability to End User and End User's exclusive remedy under this warranty is limited to the repair or replacement in kind of any defective product within its lifetime (as CAPITAL SAFETY in its sole discretion determines and deems appropriate). No oral or written information or advice given by CAPITAL SAFETY, its distributors, directors, officers, agents or employees shall create any different or additional warranties or in any way increase the scope of this warranty. CAPITAL SAFETY will not accept liability for defects that are the result of product abuse, misuse, alteration or modification, or for defects that are due to a failure to install, maintain, or use the product in accordance with the manufacturer's instructions.

CAPITAL SAFETY'S WARRANTY APPLIES ONLY TO THE END USER. THIS WARRANTY IS THE ONLY WARRANTY APPLICABLE TO OUR PRODUCTS AND IS IN LIEU OF ALL OTHER WARRANTIES AND LIABILITIES, EXPRESSED OR IMPLIED. CAPITAL SAFETY EXPRESSLY EXCLUDES AND DISCLAIMS ANY IMPLIED WARRANTIES OF MERCHANTABILITY OR FITNESS FOR A PARTICULAR PURPOSE, AND SHALL NOT BE LIABLE FOR INCIDENTAL, PUNITIVE OR CONSEQUENTIAL DAMAGES OF ANY NATURE, INCLUDING WITHOUT LIMITATION, LOST PROFITS, REVENUES, OR PRODUCTIVITY, OR FOR BODILY INJURY OR DEATH OR LOSS OR DAMAGE TO PROPERTY, UNDER ANY THEORY OF LIABILITY, INCLUDING WITHOUT LIMITATION, CONTRACT, WARRANTY, STRICT LIABILITY, TORT (INCLUDING NEGLIGENCE) OR OTHER LEGAL OR EQUITABLE THEORY.

GARANTÍA LIMITADA DE POR VIDA

Garantía para el usuario final: D B Industries, Inc., que opera bajo el nombre de CAPITAL SAFETY USA ("CAPITAL SAFETY") garantiza al usuario final original ("Usuario final") que sus productos están libres de defectos de materiales y de mano de obra en condiciones normales de uso y mantenimiento. Esta garantía se extiende durante la vida útil del producto a partir de la fecha en que el Usuario final adquiere el producto, nuevo y sin uso, a un distribuidor autorizado de CAPITAL SAFETY. La entera responsabilidad de CAPITAL SAFETY hacia el Usuario final y el remedio exclusivo para el Usuario final bajo esta garantía están limitados a la reparación o el reemplazo por materiales de todo producto defectuoso dentro de su vida útil (según CAPITAL SAFETY lo determine y considere apropiado a su solo criterio). Ninguna información o asesoramiento, oral o escrito, proporcionado por CAPITAL SAFETY, sus distribuidores, directores, funcionarios, agentes o empleados creará una garantía diferente o adicional ni aumentará de ninguna manera el alcance de esta garantía. CAPITAL SAFETY no aceptará responsabilidad por defectos resultantes del abuso, el uso incorrecto, la alteración o la modificación del producto, ni por defectos resultantes de no respetar las instrucciones del fabricante durante la instalación, el mantenimiento o el uso del producto.

LA GARANTÍA DE CAPITAL SAFETY SE APLICA ÚNICAMENTE AL USUARIO FINAL. ESTA GARANTÍA ES LA ÚNICA GARANTÍA QUE SE APLICA A NUESTROS PRODUCTOS Y REEMPLAZA A TODAS LAS OTRAS GARANTÍAS Y RESPONSABILIDADES, EXPRESAS O IMPLÍCITAS. CAPITAL SAFETY EXPRESAMENTE EXCLUYE Y RENUNCIA A TODAS LAS GARANTÍAS IMPLÍCITAS DE COMERCIABILIDAD O APTITUD PARA UN PROPÓSITO PARTICULAR, Y NO SERÁ RESPONSABLE POR DAÑOS INCIDENTALES, PUNITIVOS O EMERGENTES DE NINGUNA NATURALEZA, INCLUYENDO SIN LIMITACIÓN PÉRDIDAS DE INGRESOS, GANANCIAS O PRODUCTIVIDAD; NI POR LESIONES CORPORALES O MUERTE, O PÉRDIDA DE O DAÑO A LA PROPIEDAD, BAJO CUALQUIER TEORÍA DE RESPONSABILIDAD, INCLUYENDO SIN LIMITACIÓN CONTRATO, GARANTÍA, RESPONSABILIDAD ESTRICTA, AGRAVIO (INCLUIDA NEGLIGENCIA) O CUALQUIER OTRA TEORÍA LEGAL O EQUITATIVA.



A Capital Safety Company

CSG USA & Latin America

3833 SALA Way
Red Wing, MN 55066-5005
Toll Free: 800.328.6146
Phone: 651.388.8282
Fax: 651.388.5065
solutions@capitalsafety.com

CSG Canada

260 Export Boulevard
Mississauga, ON L5S 1Y9
Phone: 905.795.9333
Toll-Free: 800.387.7484
Fax: 888.387.7484
info.ca@capitalsafety.com

CSG Northern Europe

5a Merse Road
North Moons, Moat
Reditch, Worcestershire, UK
B98 9HL
Phone: + 44 (0)1527 548 000
Fax: + 44 (0)1527 591 000
csgne@capitalsafety.com

**CSG EMEA
(Europe, Middle East, Africa)**

Le Broc Center
Z.I. 1ère Avenue
5600 M B.P. 15 06511
Carros
Le Broc Cedex
France
Phone: + 33 4 97 10 00 10
Fax: + 33 4 93 08 79 70
information@capitalsafety.com

CSG Australia & New Zealand

95 Derby Street
Silverwater
Sydney NSW 2128
AUSTRALIA
Phone: +(61) 2 8753 7600
Toll-Free : 1 800 245 002 (AUS)
Toll-Free : 0800 212 505 (NZ)
Fax: +(61) 2 87853 7603
sales@capitalsafety.com.au

CSG Asia

Singapore:
16S, Enterprise Road
Singapore 627666
Phone: +65 - 65587758
Fax: +65 - 65587058
inquiry@capitalsafety.com

Shanghai:

Rm 1406, China Venturetech Plaza
819 Nan Jing Xi Rd,
Shanghai 200041, P R China
Phone: +86 21 62539050
Fax: +86 21 62539060

www.capitalsafety.com



Certificate No. FM 39709